

# DH485 Router/B

## User Manual

A-DH485R/B

Document No. D120-016

08/2022

Revision 1.6



# CONTENTS

1. Preface .....	5
1.1. Introduction to the DH485 Router/B .....	5
1.2. Features.....	8
1.3. Architecture.....	9
1.4. Additional Information.....	11
1.5. Support.....	12
2. Installation .....	13
2.1. Module Layout .....	13
2.2. Module Mounting .....	14
2.3. Power .....	16
2.4. RS232/DH485 Port .....	16
2.5. DH485 Termination .....	17
2.6. Ethernet Ports .....	17
3. Setup .....	18
3.1. Install Configuration Software .....	18
3.2. Network Parameters .....	18
3.3. Creating a New Project.....	22
3.4. Import from Series A DH485 Router .....	25
3.5. DH485 parameters .....	26
3.6. Message Routing .....	31
3.6.1. Transparent (PCCC) Mode .....	31
3.6.2. Reactive Tag Mode.....	40
3.6.3. Scheduled Tag Mode.....	44
3.6.4. Unscheduled Mode.....	48
3.6.5. AIC Mode.....	48
3.7. Module Download.....	48
3.8. RSLogix 5000 Configuration .....	50
3.8.1. Add Module to I/O Configuration.....	50
3.8.2. Importing UDTs and Mapping Routines .....	52
4. Operation .....	55
4.1. Message Routing .....	55

4.2.	RSLogix 5000 assemblies .....	55
4.2.1.	Input Assembly.....	56
4.2.2.	Output Assembly.....	58
4.3.	Unscheduled Messaging .....	58
4.4.	Transparent Messaging.....	62
5.	Diagnostics .....	64
5.1.	LEDs .....	64
5.2.	Module Status Monitoring in Slate .....	65
5.3.	DH485 Packet Capture .....	74
5.4.	Module Event Log.....	76
5.5.	Web Server.....	78
6.	Technical Specifications .....	79
6.1.	Dimensions.....	79
6.2.	Electrical .....	80
6.3.	Environmental.....	80
6.4.	Ethernet.....	81
6.5.	Serial Port (RS232).....	81
6.6.	Serial Port (DH485).....	81
6.7.	DH485.....	82
6.8.	Certifications .....	82
7.	Appendix A – Connection Diagrams .....	83
7.1.	DH485R/B – 1747-AIC .....	83
7.2.	DH485R/B – SLC500, 5/01, 5/02, 5/03 (Direct).....	84
7.3.	DH485R/B - MicroLogix 1100 / 1400.....	85
7.4.	DH485R/B - MicroLogix 1500 (RS232).....	86
7.5.	DH485R/B – SLC5/04 (RS232) .....	87
8.	Index.....	88

# Revision History

Revision	Date	Comment
1.0	12 August 2019	Initial document
1.1	12 Sep 2019	Correct wiring label. Added Appendix A – Connection Diagrams
1.2	15 October 2019	Added ODVA Conformance Mark
1.3	3 February 2020	Added DH485 Ground connection and bridge option. Corrected DH485 polarity labels.
1.4	4 March 2022	Added option to have DH485 on RS232 or RS485 Allow two additional PCCC IP Addresses with DH485 nodes numbers.
1.5	4 August 2022	Added information required for UL regarding open type device enclosures.
1.6	5 August 2022	Updated SLC Direct wiring to include SLC500, 5/01 and 5/02 variants.

# 1. PREFACE

## 1.1. INTRODUCTION TO THE DH485 ROUTER/B

This manual describes the installation, operation, and diagnostics of the Aparian DH485 Router Series B. The DH485 Router/B provides intelligent data routing between EtherNet/IP and DH485 which can help simplify the migration from MicroLogix and SLC systems to ControlLogix or CompactLogix platforms, where a DH485 interface is required.

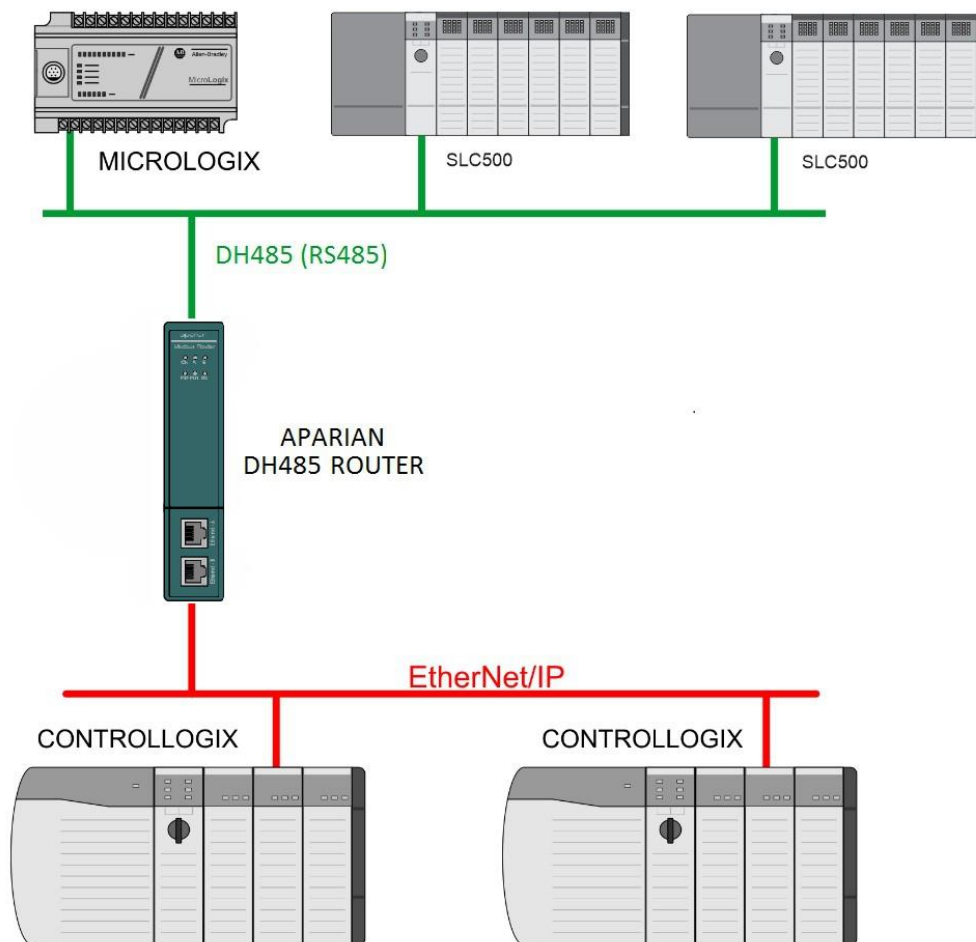

Figure 1.1. - Example of a typical network setup

The DH485 Router/B can also be used to program Allen-Bradley SLC5/03 PLCs via Ethernet. This is especially useful with certain legacy controllers that do not support Ethernet.

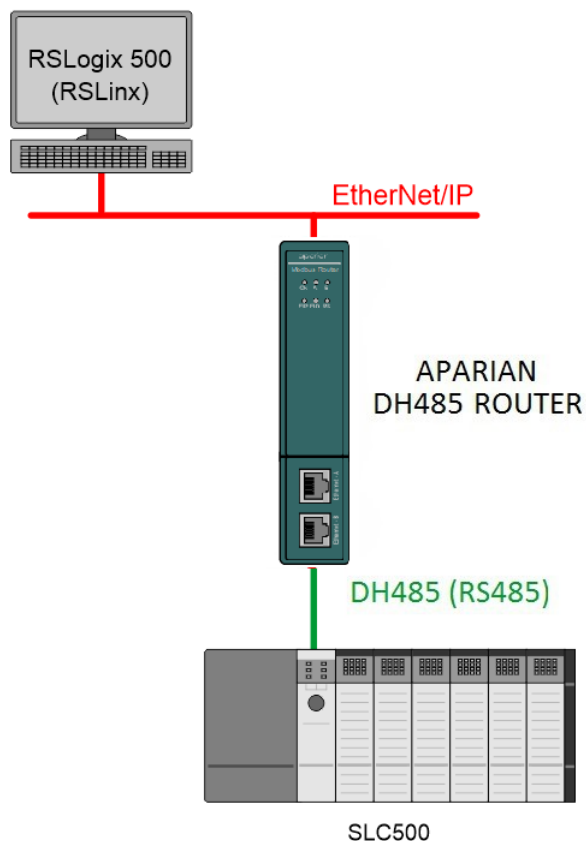

Figure 1.2. – Example of Programming a SLC5/03 Controller via the DH485 Router/B

The DH485 Router/B can also be used to connect newer PanelView Plus and PanelView 800 devices to a range of Rockwell Automation controllers. This is especially useful where newer PanelView Plus devices (supporting only Ethernet) are required to connect to controllers (new and old) via DH485.

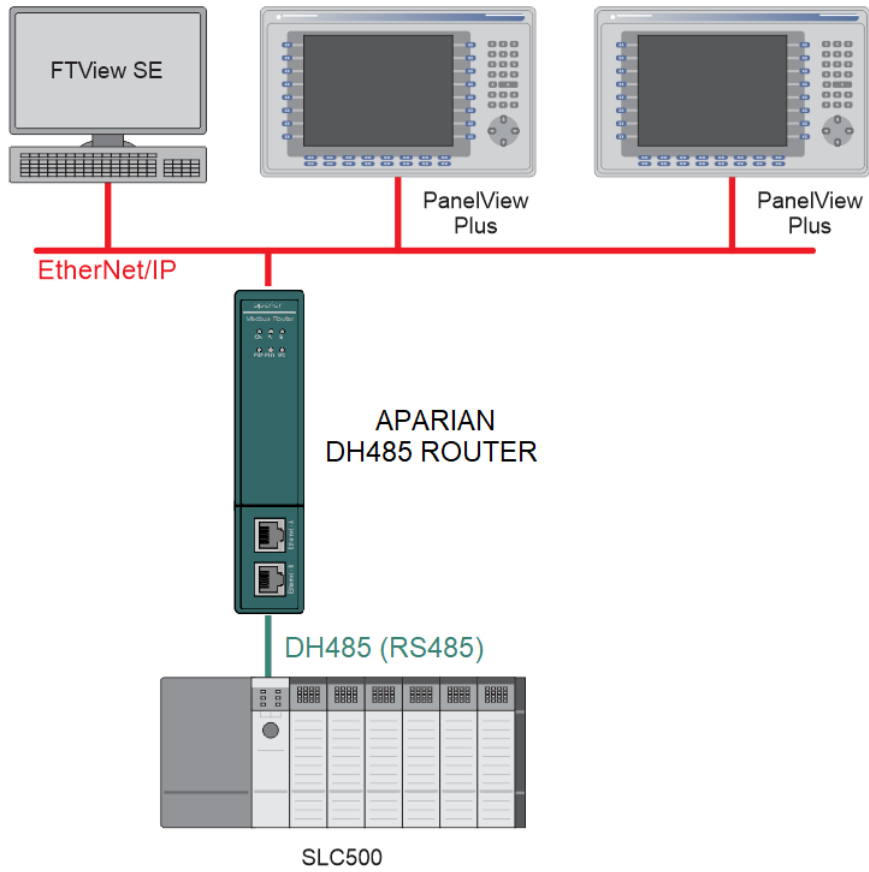

Figure 1.3. – Example of connecting a PanelView to a SLC500 Controller via the DH485 Router/B

## 1.2. FEATURES

The DH485 Router/B is able to transfer data from a DH485 device to a maximum of eight Logix controllers. The module operates in one of four modes, simplifying the configuration for all applications.

Mode	Description	Message Initiator
Transparent PCCC	The DH485 Router/B will redirect DH485 PCCC messages to a Logix controller at a preconfigured EtherNet/IP path. Logix PLC Mapping configuration may also be required. <b>This mode also enables remote programming using RSLogix 500.</b>	Remote Device
Reactive Tag	The DH485 Router/B will convert DH485 messages to Logix controller tag reads or tag writes. No Logix PLC Mapping configuration is required.	Remote Device
Scheduled Tag	The DH485 Router/B transfers data between a DH485 device and a number of Logix tags, using a preconfigured scheduled. No Logix or remote device configuration is required.	DH485 Router/B
Unscheduled	The DH485 Router/B transfers messages received from a Logix Message Instruction.	Logix (Msg)
AIC	This will allow the user to connect a RS232 device (e.g. MicroLogix 1400) to a the DH485 network via the isolated DH485 port of the DH485 Router/B. This can be used as a direct replacement for the discontinued NET-AIC module.	N/A

Table 1.1. – Modes of Operation

In Transparent PCCC mode the user will be able to connect to, and program, SLC5/03 PLCs.

The DH485 Router/B is configured using the Aparian Slate application. This program can be downloaded from [www.aparian.com](http://www.aparian.com) free of charge. Slate offers various configuration methods, including a controller tag browser.

Hereafter the DH485 Router/B will be referred to as the **module**.

The module can operate in both a Logix “owned” and standalone mode. With a Logix connection the input and output assemblies will provide additional diagnostics information which will be available in the Logix controller environment.

The module’s DH485 port is used for DH485 communication and uses a terminal block for convenient installation.



A built-in webserver provides detailed diagnostics of system configuration and operation, including the display of received DH485 communication packets, without the need for any additional software.

### 1.3. ARCHITECTURE

The figure below provides an example of the typical network setup.

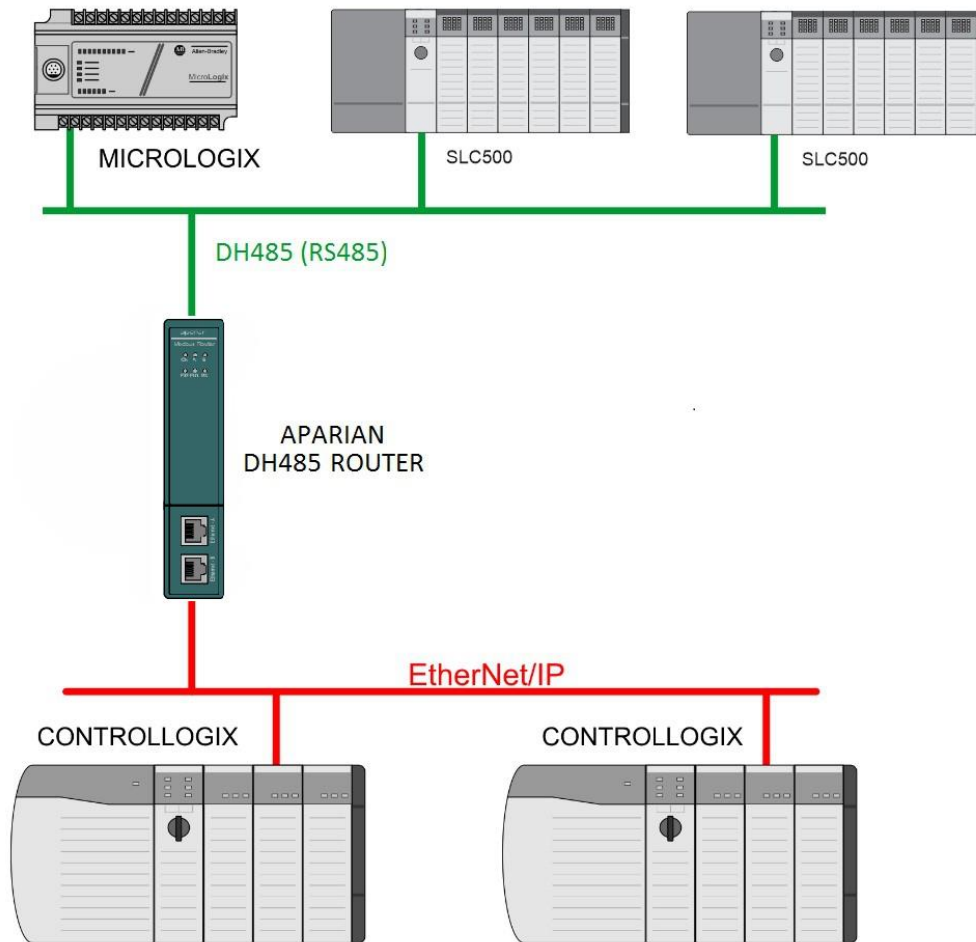

Figure 1.4. - Example of a typical network setup

By converting and redirecting DH485 messages from legacy devices to EtherNet/IP, the module provides an interface for data exchange to Allen-Bradley ControlLogix and CompactLogix platforms.

The DH485 Router/B can be used in redundant Logix controller systems.

Systems that rely on a central ControlLogix communicating to a number of remote DH485 devices, e.g. MicroLogix and SLC stations, may find the DH485 Router/B useful when upgrading to newer ControlLogix processors. These systems can easily be upgraded using the DH485 Router/B without affecting the existing and often costly wireless infrastructure.

The DH485 Router/B in conjunction with the DF1 Router can be used to replace both 1761-NET-ENI and 1761-NET-AIC. The old network architecture used the NET-ENI and NET-AIC to allow the user to use Ethernet to connect to various SLC, PLC5, and MicroLogix controllers as shown below.

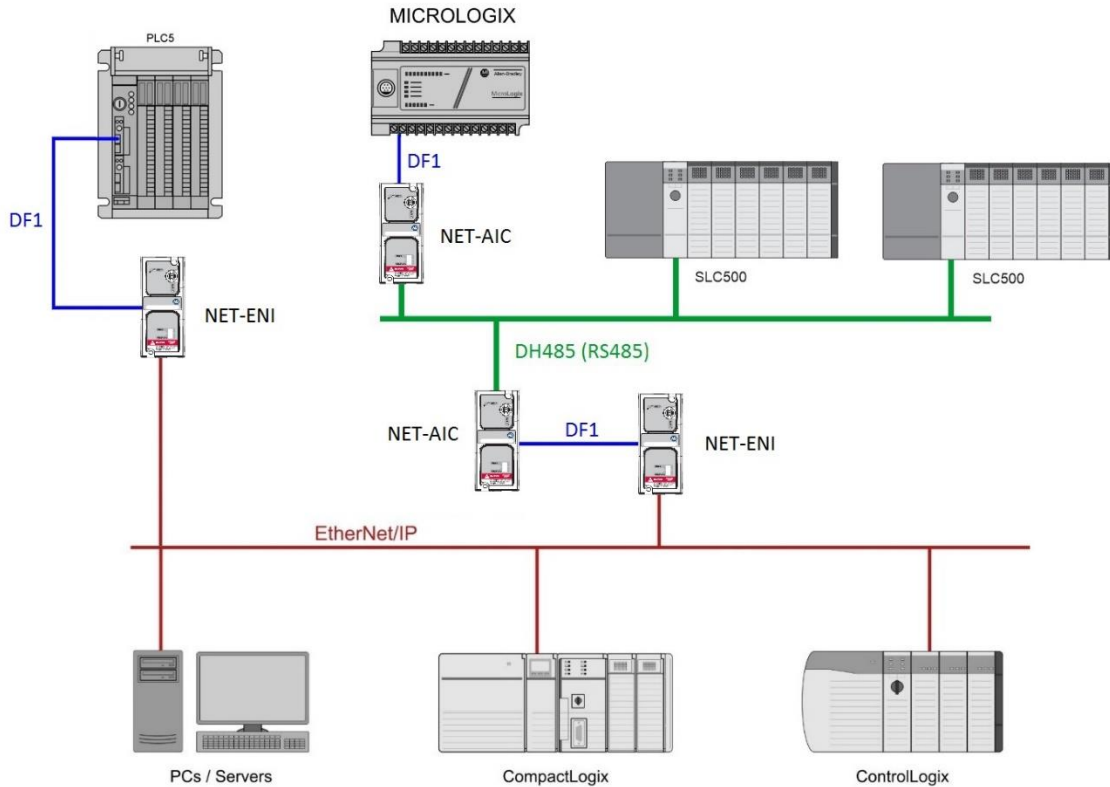

Figure 1.5. - Example of an old network setup

The DH485 Router/B and DF1 Router allows the user to directly route the DF1 and DH485 networks to EtherNet/IP as shown below:

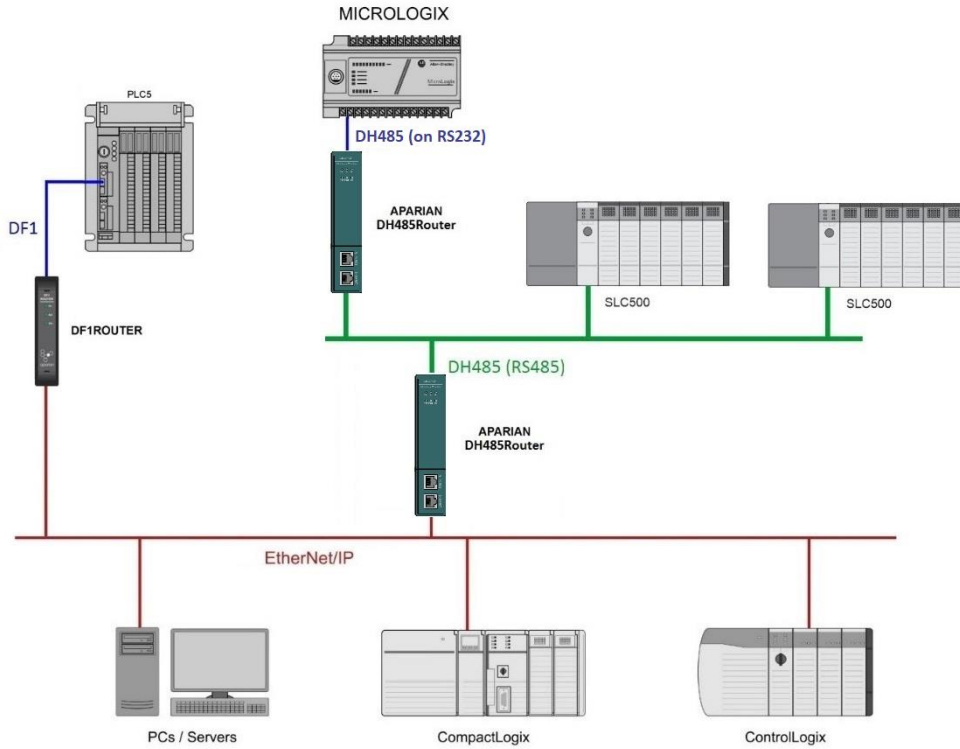

Figure 1.6. - Example of a new network setup

## 1.4. ADDITIONAL INFORMATION

The following documents contain additional information that can assist the user with the module installation and operation.

Resource	Link
Slate Installation	<a href="https://www.aparian.com/software/slate">https://www.aparian.com/software/slate</a>
DH485 Router/B User Manual DH485 Router/B Datasheet Application Notes Example Code & UDTs	<a href="https://www.aparian.com/products/dh485routerb">https://www.aparian.com/products/dh485routerb</a>
Ethernet wiring standard	<a href="http://www.cisco.com/c/en/us/td/docs/video/cds/cde/cde205_220_420/installation/guide/cde205_220_420_hig/Connectors.html">www.cisco.com/c/en/us/td/docs/video/cds/cde/cde205_220_420/installation/guide/cde205_220_420_hig/Connectors.html</a>
CIP Routing	The CIP Networks Library, Volume 1, Appendix C:Data Management
Map PLC/SLC messages	SLC to CompactLogix Migration Guide: Chapter 3 – Map PLC/SLC Messages (1769-ap001_-en-p.pdf) EtherNet/IP Network Configuration: Chapter 5 – Mapping Tags (enet-um001_-en-p.pdf)

Table 1.2. - Additional Information

## 1.5. SUPPORT

Technical support is provided via the Web (in the form of user manuals, FAQ, datasheets etc.) to assist with installation, operation, and diagnostics.

For additional support the user can use either of the following:

Resource	Link
Contact Us web link	<a href="http://www.aparian.com/contact-us">www.aparian.com/contact-us</a>
Support email	<a href="mailto:support@aparian.com">support@aparian.com</a>

Table 1.3. – Support Details

## 2. INSTALLATION

### 2.1. MODULE LAYOUT

The module has two ports at the bottom and two ethernet ports on the front of the enclosure as shown in the figure below. The ports are used for Ethernet, RS232 or DH485 serial, and power. The power port uses a three-way connector which is used for the DC power supply positive and negative (or ground) voltage as well as the earth connection.

The Ethernet cable must be wired according to industry standards which can be found in the additional information section of this document.

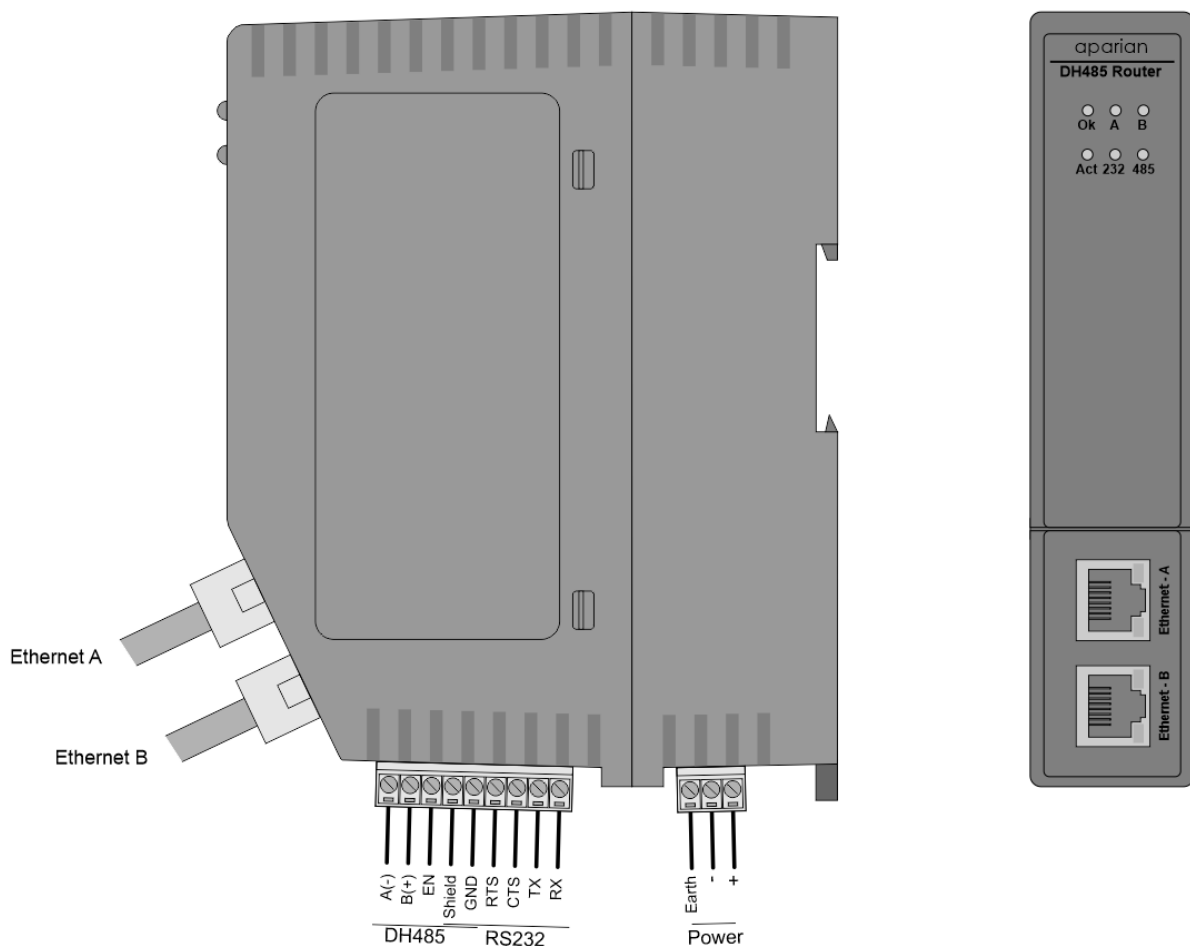

Figure 2.1. - DH485 Router/B side and front view

The module provides six diagnostic LEDs as shown in the front view figure above. These LEDs are used to provide information regarding the module system operation, the Ethernet interface, and the auxiliary communication interface (DH485).

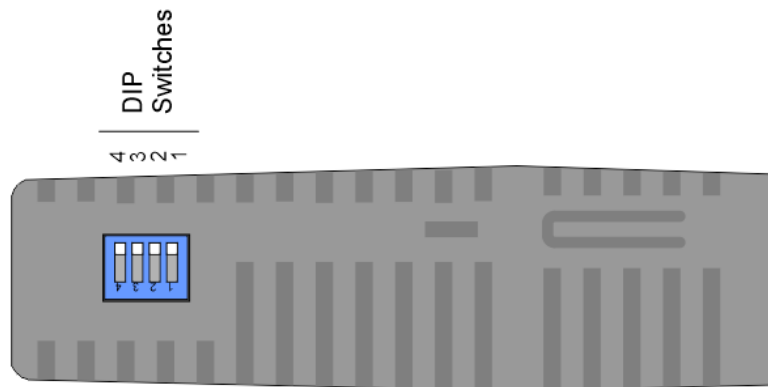

Figure 2.2. – DH485 Router/B top view

The module provides four DIP switches at the top of the enclosure as shown in the top view figure above.

DIP Switch	Description
DIP Switch 1	Used to force the module into “Safe Mode”. When in “Safe Mode” the module will not load the application firmware and will wait for new firmware to be downloaded. This should only be used in the rare occasion when a firmware update was interrupted at a critical stage.
DIP Switch 2	This will force the module into DHCP mode which is useful when the user has forgotten the IP address of the module.
DIP Switch 3	Reserved
DIP Switch 4	When this DIP Switch is set at bootup it will force the module Ethernet IP address to 192.168.1.100 and network mask 255.255.255.0. The user can then switch the DIP switch off and assign the module a static IP address if needed.

Table 2.1. - DIP Switch Settings

## 2.2. MODULE MOUNTING



**NOTE:** This module is an open-type device and is meant to be installed in an enclosure suitable for the environment such that the equipment is only accessible with the use of a tool.

The module provides a DIN rail clip to mount onto a 35mm DIN rail.

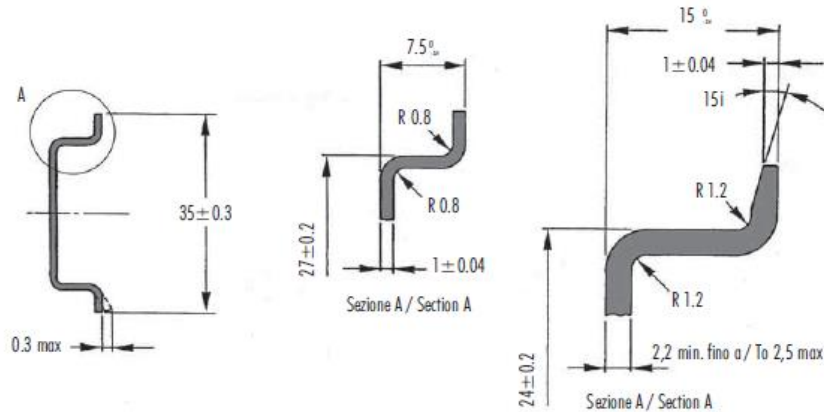

Figure 2.3 - DIN rail specification

The DIN rail clip is mounted on the bottom of the module at the back as shown in the figure below. Use a flat screwdriver to pull the clip downward. This will enable the user to mount the module onto the DIN rail. Once the module is mounted onto the DIN rail the clip must be pushed upwards to lock the module onto the DIN rail.

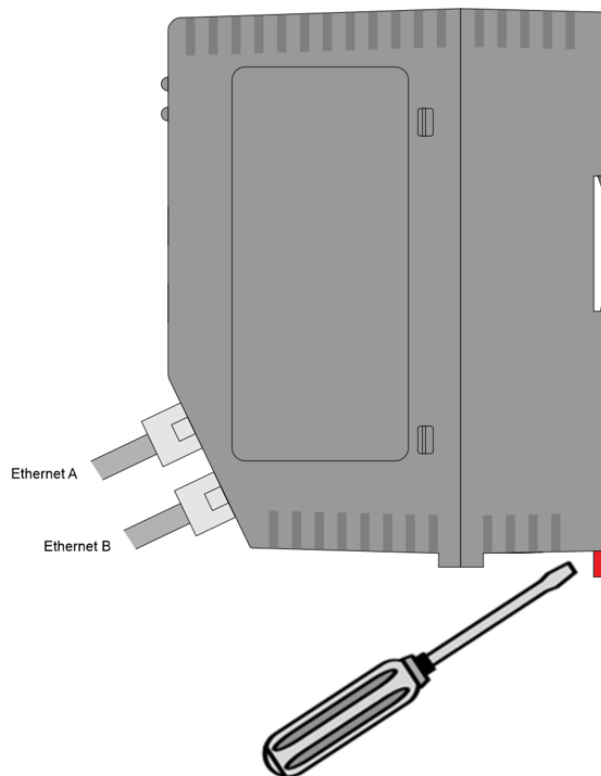

Figure 2.4 - DIN rail mouting

## 2.3. POWER

A three-way power connector is used to connect Power+, Power- (GND), and earth. The module requires an input voltage of 10 – 32Vdc. **Refer** to the technical specifications section in this document.

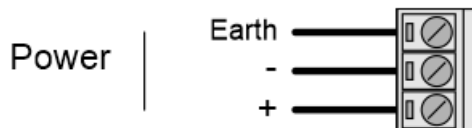

Figure 2.5 - Power connector

## 2.4. RS232/DH485 PORT

The nine-way connector is used to connect the RS232 and DH485 conductors for serial communication. The shield terminal can be used for shielded cable in high noise environments.

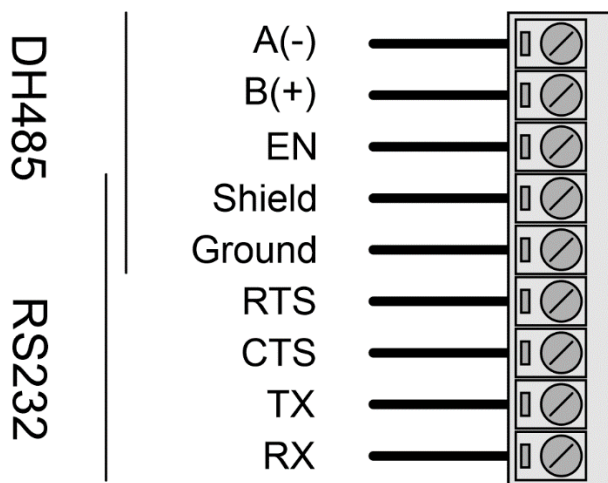

Figure 2.6 - RS232 / DH485 connector

The DH485 port provides the standard **A(-)**, **B(+)** and **Ground** conductors for DH485. For long DH485 networks, it is recommended to connect the **Ground** and enable the **DH485 Ground Bridge** option in the configuration.

The DH485 (**EN**) transmit drive enable is provided to allow the DH485 Router/B to be used with repeaters and radios that may require a transmit enable line. Note that the DH485 EN line is referenced to **Ground** and requires the **DH485 Ground Bridge** option to be enabled in the configuration.



The RS232 port provides the standard communication conductors (RX, TX, and GND) as well as hardware handshaking lines for legacy systems (RTS – Request to Send, CTS – Clear to Send).

Both RS232 and DH485 share a common cable shield connection which should be connected to the shield of the outgoing cable (RS232 and/or DH485).



**NOTE:** The shield of the RS232/DH485 port is internally connected to the power connector earth. Thus, when using a shield, it is important to connect the Earth terminal on the power connector to a clean earth. Failing to do this can lower the signal quality of the RS232/DH485 communication.



**NOTE:** When using a shielded cable, it is important that only one end of the shield is connected to earth to avoid current loops. It is recommended to connect the shield to the DH485 Router module, and not to the other DH485 device.

## 2.5. DH485 TERMINATION

All DH485 networks need to be terminated at the extremities (BOTH start and end-points) of the communication conductor. The termination for the DH485 network can be enabled/disabled via the module configuration. Enabling the termination will connect an internal 125 Ohm resistor across the positive B(+) and negative A(-) conductors of the DH485 network.

## 2.6. ETHERNET PORTS

The Ethernet connectors should be wired according to industry standards. **Refer** to the additional information section in this document for further details.

The module has an embedded switch connecting the two Ethernet ports.

## 3. SETUP

### 3.1. INSTALL CONFIGURATION SOFTWARE

All the network setup and configuration of the module is achieved by means of the Aparian Slate device configuration environment. This software can be downloaded from <http://www.aparian.com/software/slate>.

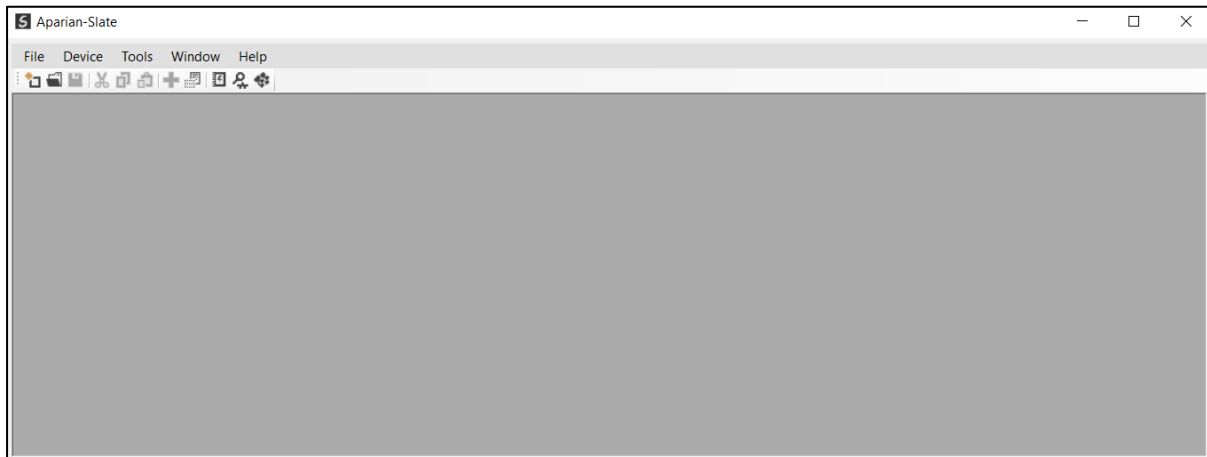

Figure 3.1. - Aparian Slate Environment

### 3.2. NETWORK PARAMETERS

The module will have DHCP (Dynamic Host Configuration Protocol) enabled as factory default. Therefore, a DHCP server must be used to provide the module with the required network parameters (IP address, subnet mask, etc.). There are a number of DHCP utilities available, however it is recommended that the DHCP server in Slate be used.

Within the Slate environment, the DHCP server can be found under the Tools menu.

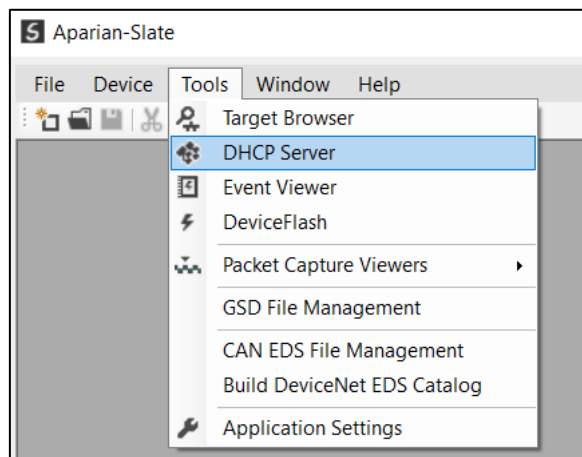

Figure 3.2. - Selecting DHCP Server

Once opened, the DHCP server will listen on all available network adapters for DHCP requests and display their corresponding MAC addresses.

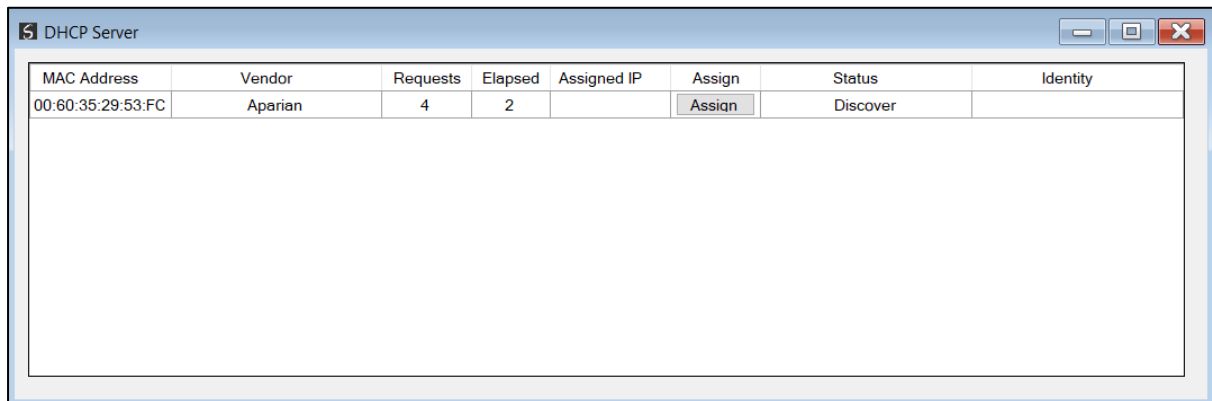

Figure 3.3. - DHCP Server



**NOTE:** If the DHCP requests are not displayed in the DHCP Server it may be due to the local PC's firewall. During installation the necessary firewall rules are automatically created for the Windows firewall.

Another possibility is that another DHCP Server is operational on the network and it has assigned the IP address.

To assign an IP address, click on the corresponding "Assign" button. The IP Address Assignment window will open.

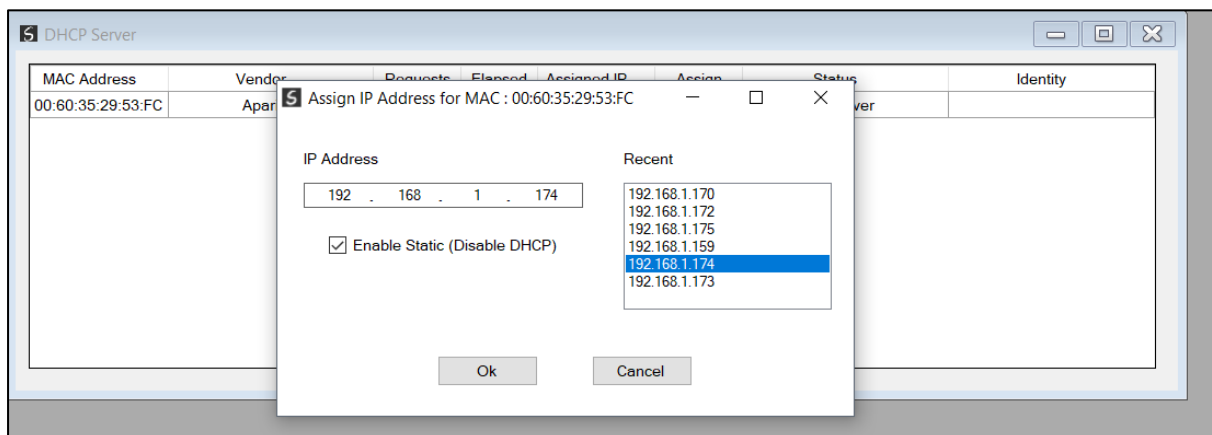

Figure 3.4. - Assigning IP Address

The required IP address can then be either entered, or a recently used IP address can be selected by clicking on an item in the Recent List.

If the "Enable Static" checkbox is checked, then the IP address will be set to static after the IP assignment, thereby disabling future DHCP requests.

Once the IP address window has been accepted, the DHCP server will automatically assign the IP address to the module and then read the Identity object Product name from the device.

The successful assignment of the IP address by the device is indicated by the green background of the associated row.

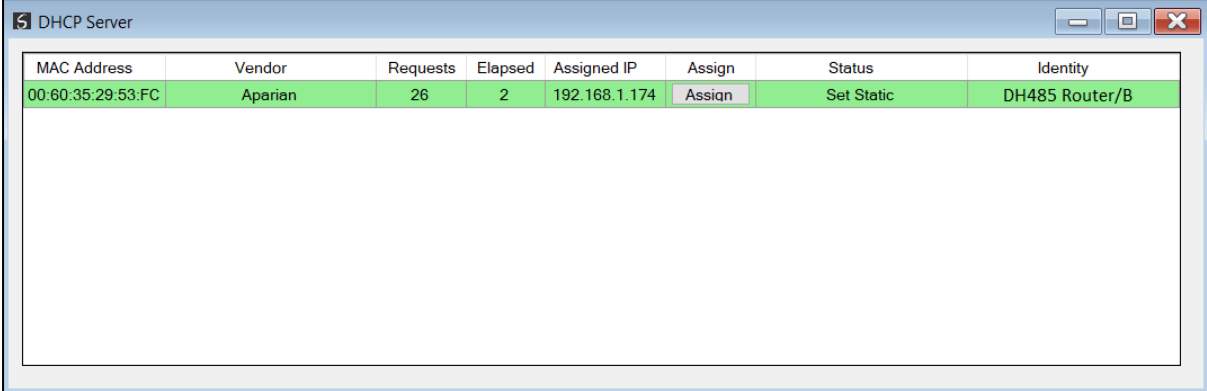

MAC Address	Vendor	Requests	Elapsed	Assigned IP	Assign	Status	Identity
00:60:35:29:53:FC	Aparian	26	2	192.168.1.174	Assign	Set Static	DH485 Router/B

Figure 3.5. - Successful IP address assignment

It is possible to force the module back into DHCP mode by powering up the device with DIP switch 2 set to the On position.

A new IP address can then be assigned by repeating the previous steps.



**NOTE:** It is important to return DIP switch 2 back to Off position, to avoid the module returning to a DHCP mode after the power is cycled again.

If the module's DIP switch 2 is in the On position during the address assignment, the user will be warned by the following message.

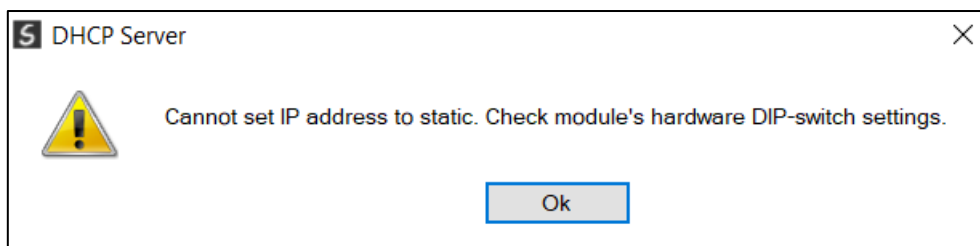

Figure 3.6. - Force DHCP warning

In addition to the setting the IP address, a number of other network parameters can be set during the DHCP process. These settings can be viewed and edited in Slate's Application Settings, in the DHCP Server tab.

Once the DHCP process has been completed, the network settings can be set using the Ethernet Port Configuration via the Target Browser.

The Target Browser can be accessed under the Tools menu.

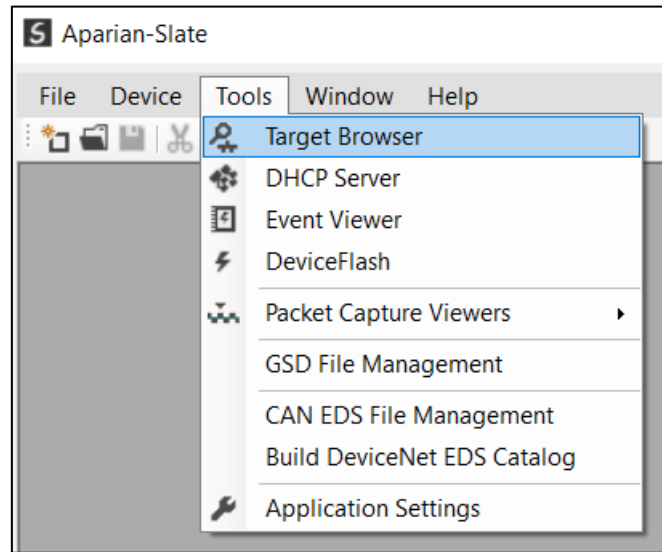

Figure 3.7. - Selecting the Target Browser

The Target Browser automatically scans the Ethernet network for EtherNet/IP devices.

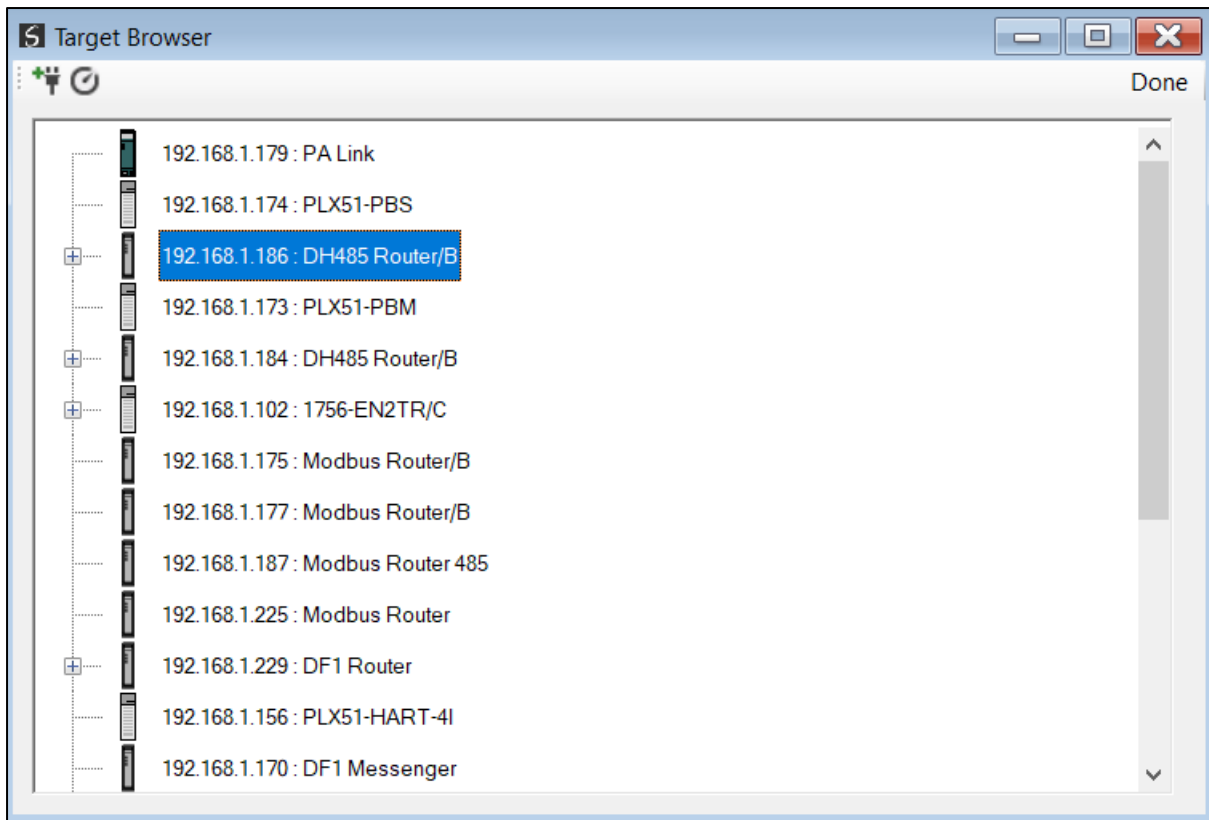

Figure 3.8. - Target Browser

Right-clicking on a device, reveals the context menu, including the Port Configuration option.

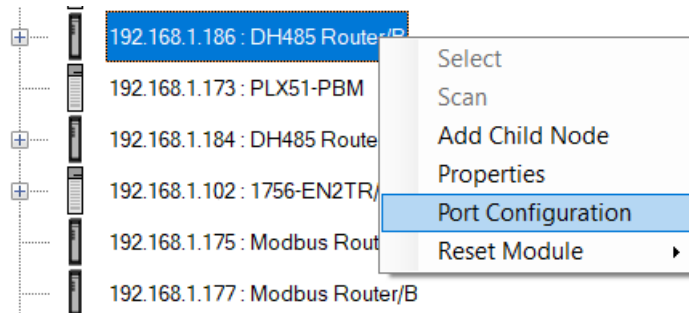

Figure 3.9. - Selecting Port Configuration

All the relevant Ethernet port configuration parameters can be modified using the Port Configuration window.

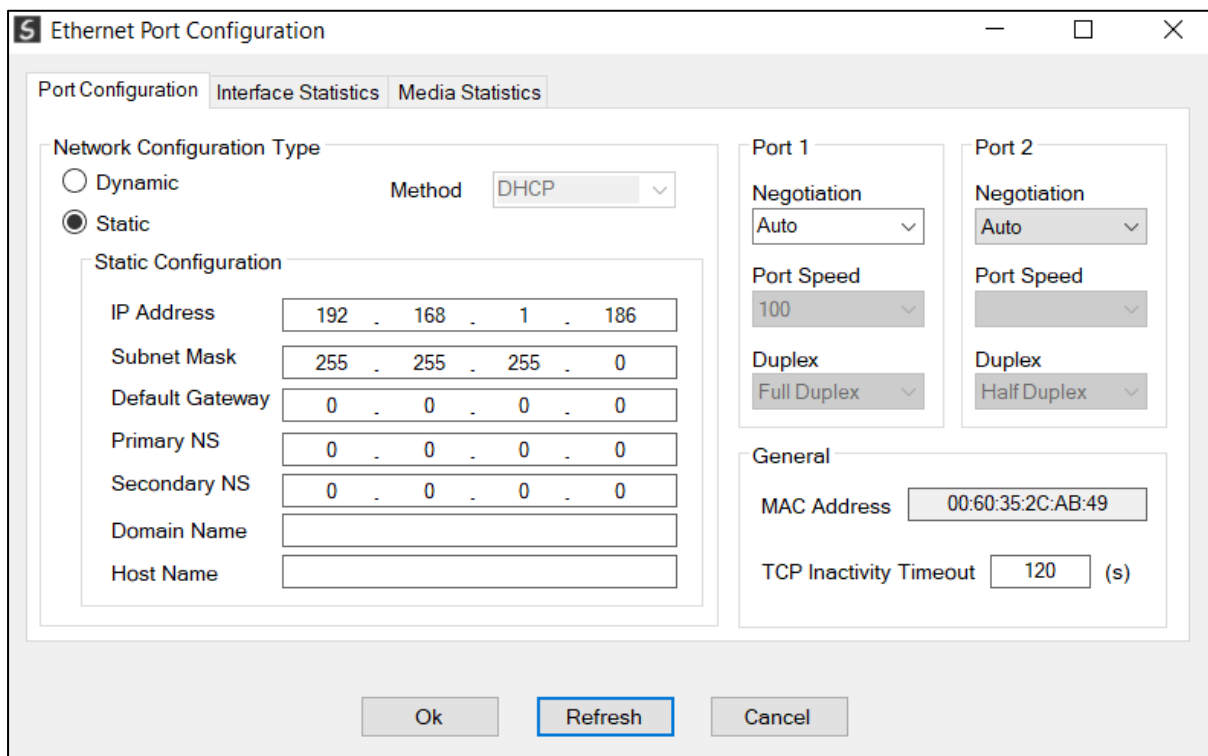

Figure 3.10. - Port Configuration

Alternatively, these parameters can be modified using Rockwell Automation's RSLinx software.

### 3.3. CREATING A NEW PROJECT

Before the user can configure the module, a new Slate project must be created. Under the File menu, select New.

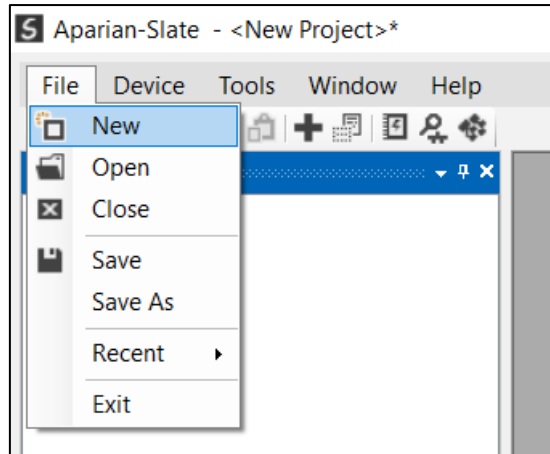

Figure 3.11. - Creating a new project

A Slate project will be created, showing the Project Explorer tree view. To save the project use the Save option under the File menu.

A new device can now be added by selecting Add under the Device menu.

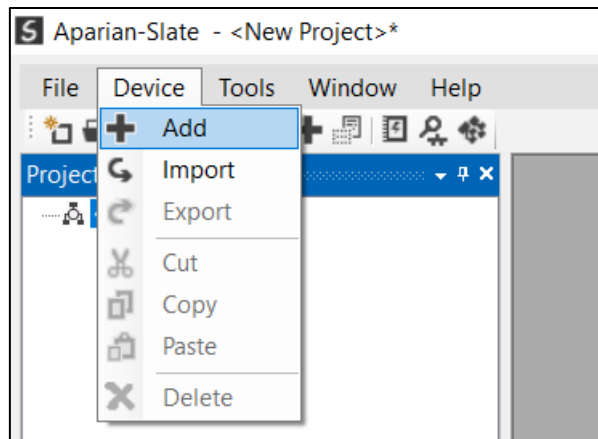

Figure 3.12. - Adding a new device

In the Add New Device window select the DH485 Router/B and click the Ok button.

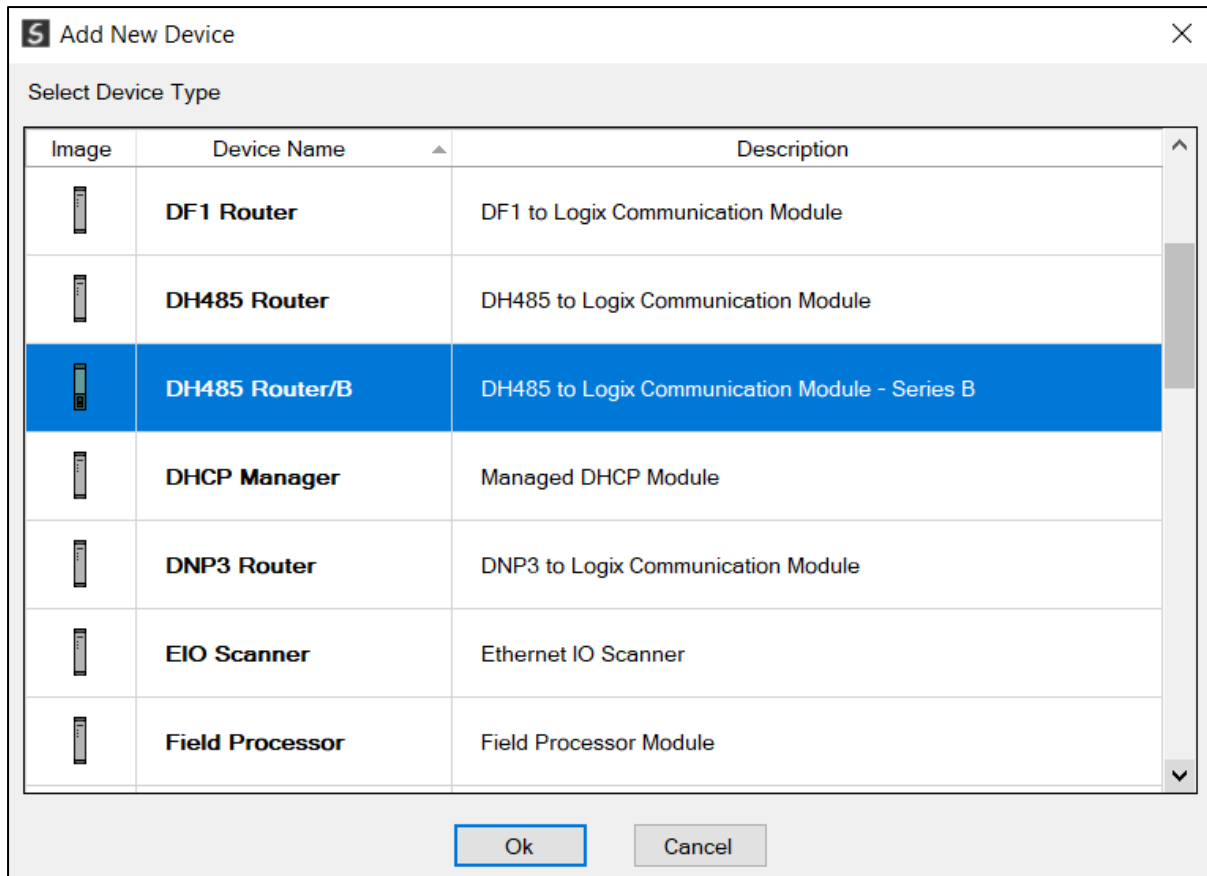

Figure 3.13 – Selecting a new DH485 Router/B

The device will appear in the Project Explorer tree as shown below, and its configuration window opened.

The device configuration window can be reopened by either double clicking the module in the Project Explorer tree or right clicking the module and selecting *Configuration*.



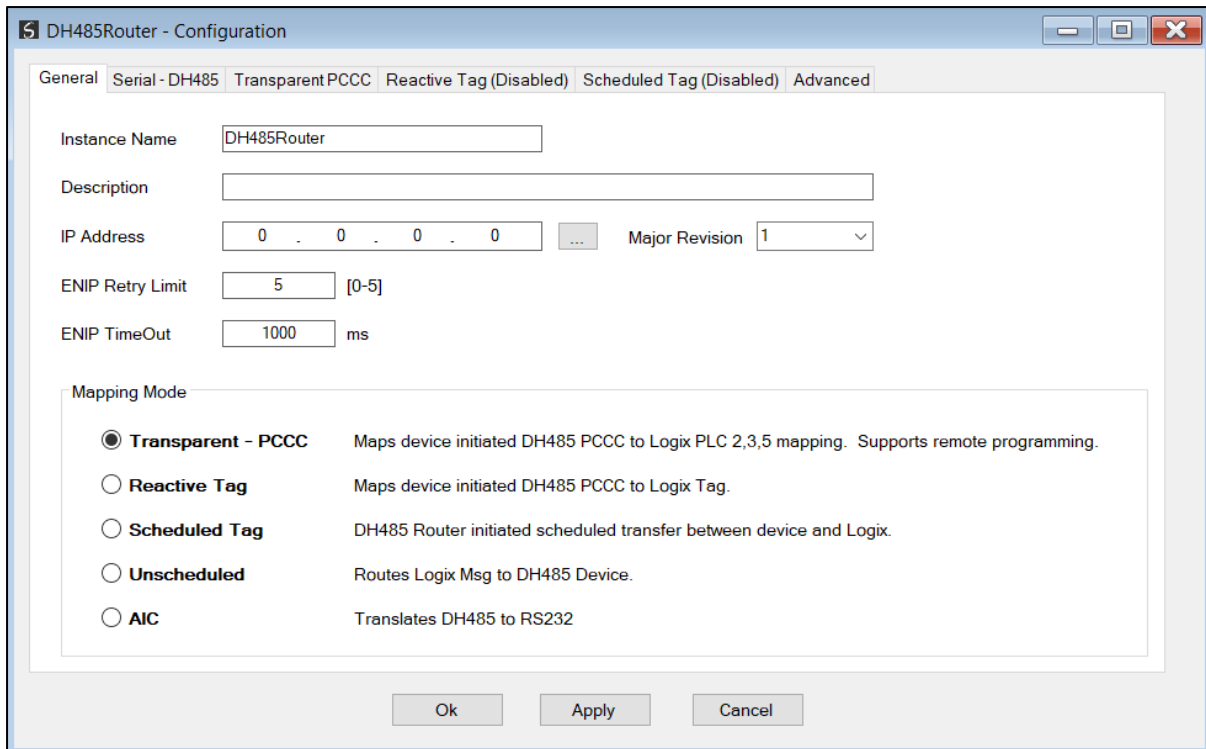

Figure 3.14. – DH485 Router/B configuration

### 3.4. IMPORT FROM SERIES A DH485 ROUTER

In applications where a Series A DH485 Router is being upgraded to a new Series B router, the configuration can be imported. Firstly, the old and new Router's need to be in the same project. This can be achieved by either adding the new DH485 Router/B in the old project, or exporting the DH485 Router (series A) from the old project and importing it into the new project.

Then, right-click on the DH485 Router/B and select the **Import from Series A** option.

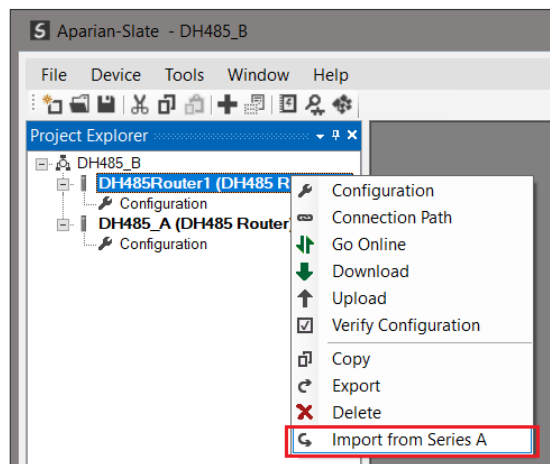

Figure 3.15. – Import from Series A option

Then, select the required DH485 Router (Series A) device and click **Ok**.

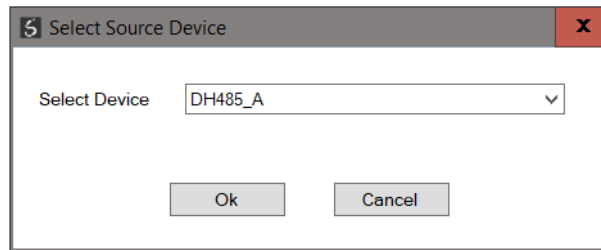

Figure 3.16. – Select Series A device for import

The configuration will then be copied into the new Series B device.

### 3.5. DH485 PARAMETERS

The DH485 parameters will be configured by Slate. The DH485 parameter configuration consists of a general configuration as well as a serial configuration. When downloading this configuration into the module it will be saved in non-volatile memory that persists when the module is powered down.



**NOTE:** When a firmware upgrade is performed the module will clear all DH485 configuration and routing maps.

The general configuration is shown in the figure below. The DH485 general configuration window is opened by either double clicking on the module in the tree or right-clicking the module and selecting **Configuration**.

The screenshot shows the 'DH485Router - Configuration' dialog box with the 'General' tab selected. The fields are as follows:

- Instance Name: DH485Router
- Description: (empty)
- IP Address: 0 . 0 . 0 . 0
- Major Revision: 1
- ENIP Retry Limit: 5 [0-5]
- ENIP TimeOut: 1000 ms
- Mapping Mode:
  - Transparent - PCCC**: Maps device initiated DH485 PCCC to Logix PLC 2,3,5 mapping. Supports remote programming.
  - Reactive Tag**: Maps device initiated DH485 PCCC to Logix Tag.
  - Scheduled Tag**: DH485 Router initiated scheduled transfer between device and Logix.
  - Unscheduled**: Routes Logix Msg to DH485 Device.
  - AIC**: Translates DH485 to RS232

Buttons at the bottom: Ok, Apply, Cancel.

Figure 3.17. - General Configuration

The general configuration consists of the following parameters:

Parameter	Description
Instance Name	This parameter is a user defined name to identify between various DH485 Router/Bs.
Description	This parameter is used to provide a more detail description of the application for the module.
Major Revision	The major revision of the module
Mapping Mode	<p>The mapping mode will determine how the DH485 messages are routed.</p> <p>When selecting <b>Transparent (PCCC) mode</b> the module will use the PCCC message exchange to read or write various tags in the Logix controller. Therefore, in this mode, the module will rely on the Logix controller to map the DH485 request to the preconfigured Logix tag.</p> <p>Communication in this mode is initiated by the remote DH485 device.</p> <p>In <b>Reactive Tag mode</b> the module will automatically route the DH485 message and function to the correct Logix tag. In this mode the DH485 Router/B will map the DH485 request to the preconfigured tag.</p> <p>Communication in this mode is initiated by the remote DH485 device.</p> <p>In <b>Scheduled Tag mode</b>, the DH485 Router/B will initiate the exchange between the remote DH485 device and Logix. Either by reading data from a DH485 device and writing it into a preconfigured Logix tag or vice versa.</p> <p>Communication in this mode is initiated by the DH485 Router/B.</p>

	<p>In <b>Unscheduled mode</b> the DH485 Router/B routes Logix messages to the remote DH485 device and returns the result. There is little configuration required in the DH485 Router/B as the routing information is configured by Logix for each message transaction.</p> <p>Communication in this mode is initiated by Logix.</p> <p>In <b>AIC mode</b> the DH485 Router/B routes has no intelligent routing, but only translates the requests from the DH485 network to RS232 and vice versa. This will serve as a direct replacement for the legacy NET-AIC module.</p> <p>Refer to the message routing section of the document for a detailed explanation of the routing operation.</p>
ENIP Retry Limit	The number of EtherNet/IP retries the module will make once no response was received from the Logix Controller.
ENIP TimeOut	The time in milliseconds after which a retry is sent. Once the first retry is sent the next retry will be sent after the same amount of time. This will repeat until the ENIP Retry Limit is reached.

Table 3.1 - General configuration parameters

The serial DH485 configuration is shown in the figure below. The DH485 Serial configuration window is opened by either double clicking on the module in the tree or right clicking the module and selecting **Configuration**. Once in the configuration window select the second tab at the top **Serial – DH485**.

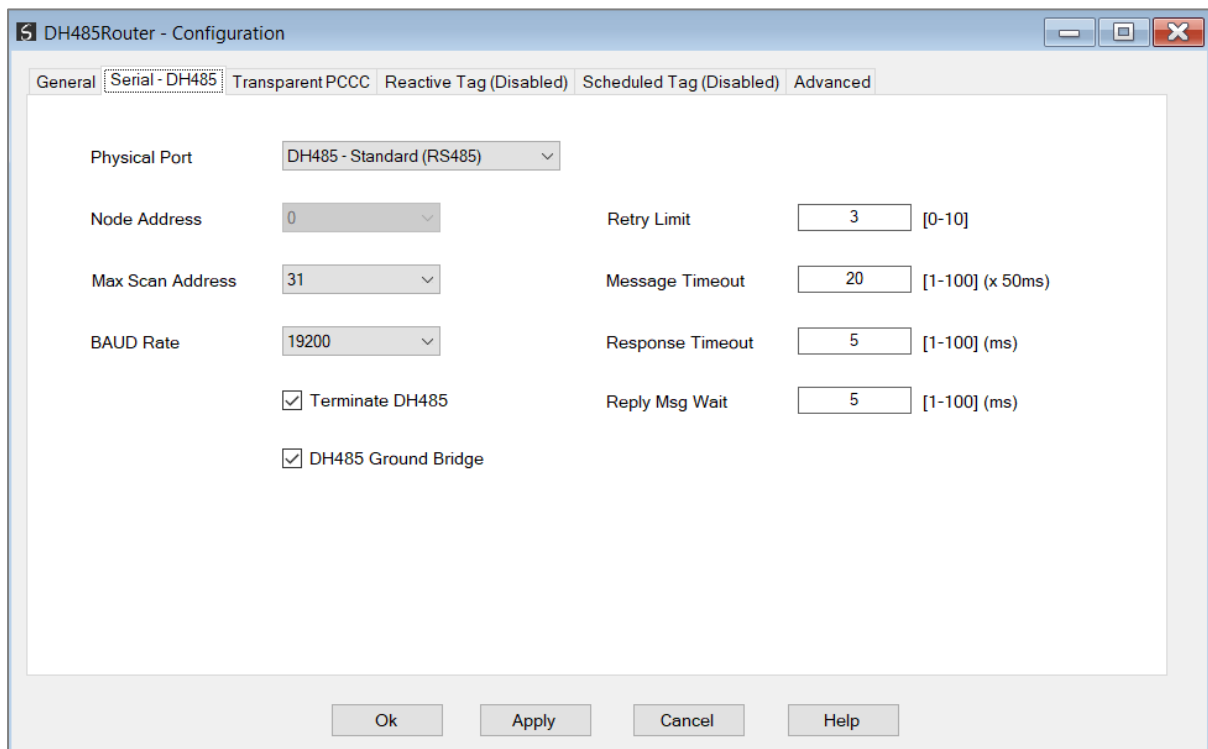

Figure 3.18 - Serial DH485 configuration

The Serial – DH485 configuration consists of the following parameters:

Parameter	Description
BAUD Rate	The BAUD rate will configure at what speed the data is send across the DH485/RS232 serial network. The module provides the following speeds: 1200, 2400, 4800, 9600, 19200, 38400, 57600, and 115200 <b>NOTE:</b> The default baud rate for DH485 is 19200.
Physical Port	The module can communicate (using DH485) or either RS485 or RS232.
Max Scan Address	This is the maximum address to which the DH485 Router/B will poll network addresses.
Node Address	The node address is only configurable in Unscheduled mode. In all other modes the node address is dynamically changed to suite the required mapping.
Retry Limit	The retry limit determines how many times the module must retry and message exchange before failing it.
Message Timeout	The Message timeout is used to determine the interval between retries when a message exchange has failed.
Reply Msg Wait	The reply message wait is the minimum delay before the DH485 reply is transmitted to the DH485 device.
Reply Timeout	The Reply timeout is used to determine when a reply has failed.
Terminate DH485	This will activate the internal 125 Ohm terminator on the DH485 (DH485) network.
DH485 Ground Bridge	Connects the isolated DH485 ground to the external Ground terminal. Note: When enabled, the isolated RS232 and DH485 grounds are connected.

Table 3.2 - Serial DH485 configuration parameters



**NOTE:** If the DH485 Router/B supports 8 data bits and 1 stop bit.

The Advanced configuration is shown in the figure below. The DH485 Router/B Advanced configuration window is opened by either double clicking on the module in the tree or right-clicking the module and selecting **Configuration**.

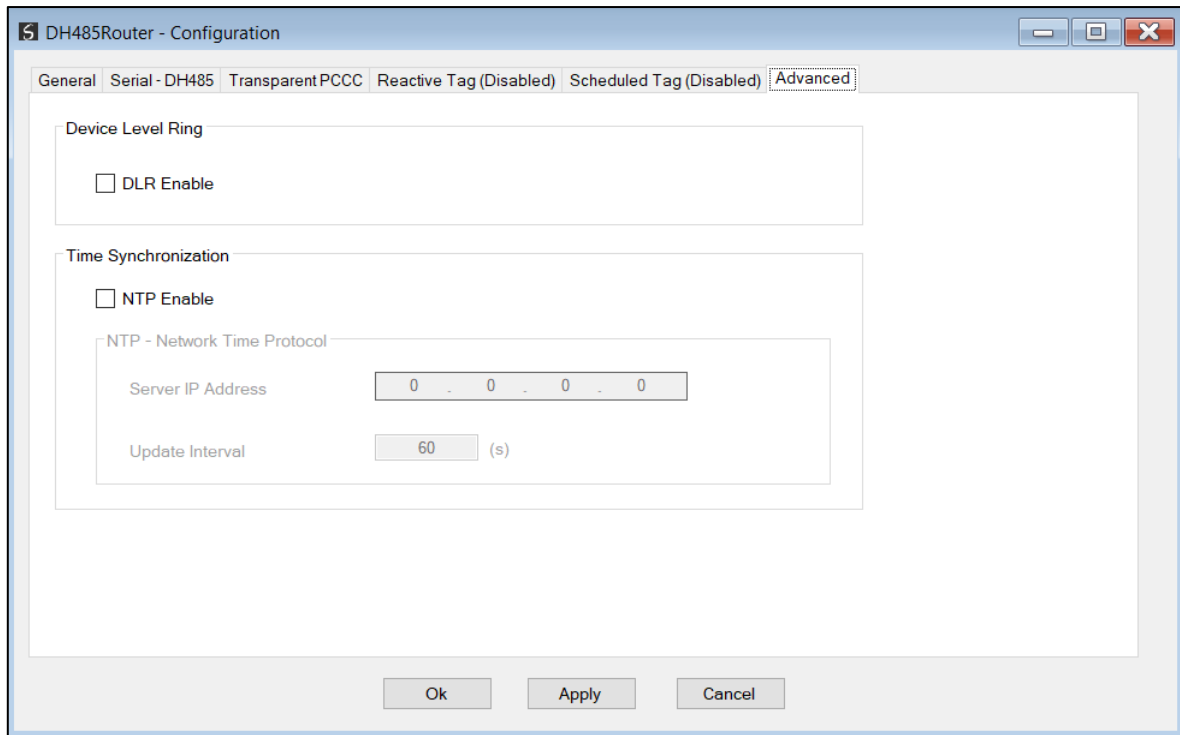

Figure 3.19 - Advanced configuration

The Advanced configuration consists of the following parameters:

Parameter	Description
DLR Enable	This must be set to enable Device Level Ring operation when the DH485 Router/B will be operating in an Ethernet DLR.
NTP Enable	The DH485 Router/B can synchronize its onboard clock to an NTP Server by enabling NTP.
NTP – Server IP Address	This setting is the IP address of the NTP Server which will be used as a time source.
NTP – Update Interval	This setting is the updated interval (in seconds) that the DH485 Router/B will request time from the NTP Server.

Table 3.3 - Advanced configuration parameters

## 3.6. MESSAGE ROUTING

The module can be configured to route DH485 data in one of five modes. As mentioned in the DH485 parameter section in this document the four modes are:

- Transparent (PCCC) mode
- Reactive Tag mode
- Schedule Tag mode
- Unscheduled mode
- AIC mode

### 3.6.1. TRANSPARENT (PCCC) MODE

The Transparent Mode can be used for redirecting messages between the DH485 and Ethernet port. This mode allows for various remote programming options and well as mapping DH485 (PCCC) messages to a Logix controller when using the Logix PLC mapping feature.

To open the transparent map configuration window by double clicking on the module in the tree or right clicking the module and selecting *Configuration*. Once in the configuration window select the third tab at the top *Transparent PCCC*. The transparent PCCC map configuration is shown in the figure below.

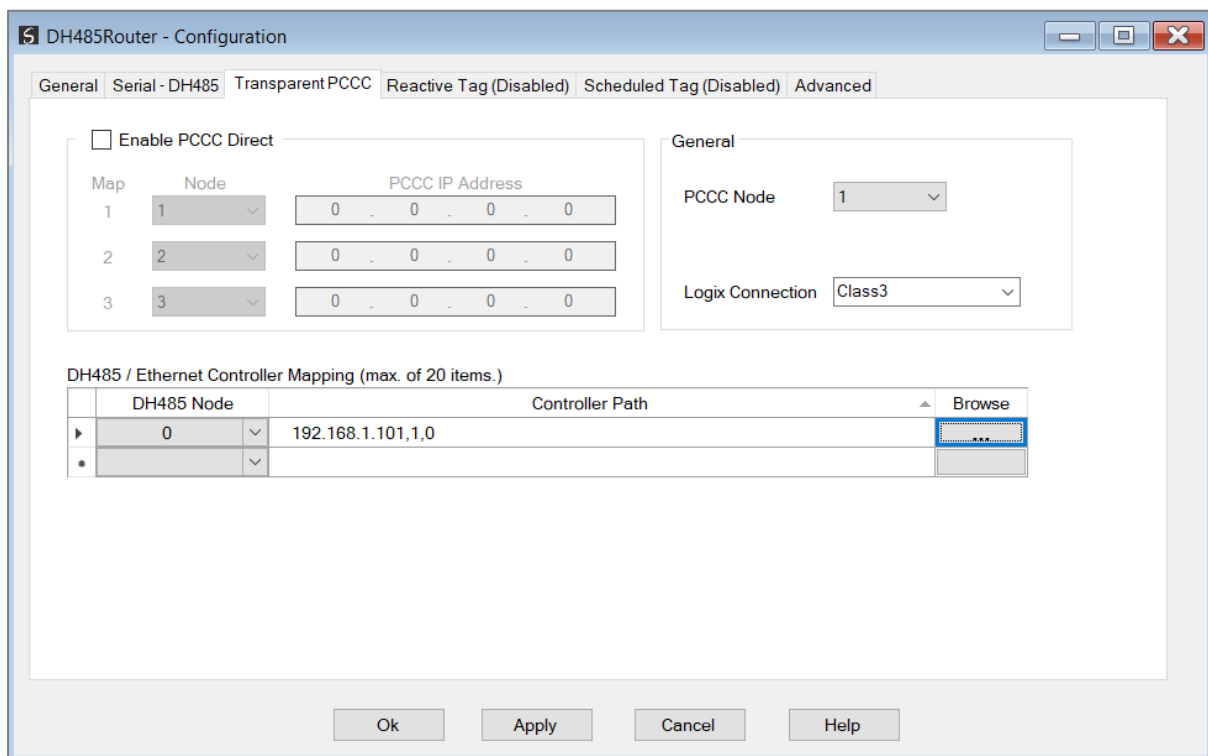

Figure 3.20 - Transparent map configuration

The module can emulate more than one destination DH485 Node Address, and thus route multiple messages to different Ethernet devices. For this reason, it is important to enter the correct associate DH485 Node address in each mapping record.

When using PCCC data messaging the connection class can be configured by selecting either Class 3 or Unconnected (UCMM) messaging. This is done by selecting from the Connection drop-down box in the Transparent PCCC tab.

The controller paths can either be entered manually or the user can browse to them by clicking the **Browse** button. The Target Browser requires the controller to be available on the network. The Target Browser will open and automatically scan for all EtherNet/IP devices.

If the Ethernet/IP module is a bridge module, it can be expanded by right-clicking on the module and selecting the Scan option.

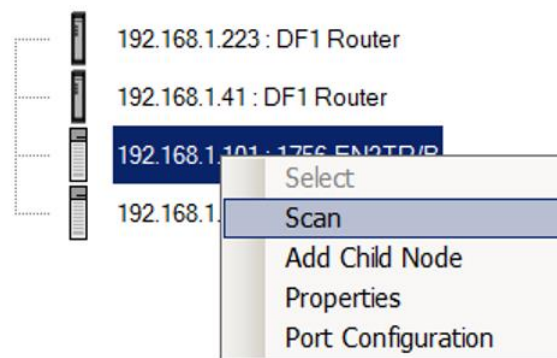

Figure 3.21. - Scanning node in the Target Browser

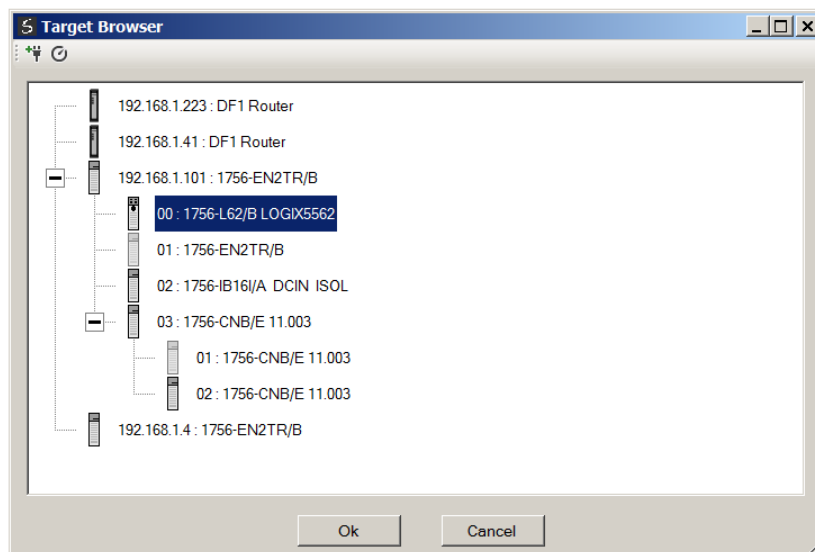

Figure 3.22. - Target Browser selection



The required controller can then be chosen by selecting it and clicking the Ok button, or by double-clicking on the controller module.

A maximum number of 20 mapping entries can be added.

Parameter	Description
DH485 Node Address	<p>This parameter is one of the destinations addresses that the DH485 Router/B will accept. When the DH485 message initiator sends a message to a specific DH485 node address that has been configured in the module, it will be accepted and routed to the paired Controller Path.</p> <p>This is the destination node address of the message, and not the source address of the DH485 device.</p>
Controller Path	<p>The Ethernet/CIP path to the end device (e.g. Logix controller). Refer to the additional information section in this document for references to details routed CIP path information. For example:</p> <p>If the controller (slot 0) is in a chassis with an Ethernet bridge (IP address 192.168.1.20) connected to the local network the user would follow the format; <i>Ethernet bridge IP address, chassis backplane port, module slot etc.</i> 192.168.1.20,1,0</p> <p>For PLC5 and SLC500/MicroLogix devices, the path should contain only the device's IP address.</p>
Enable PCCC Direct	<p>The PCCC Direct option allows the DH485 Router/B to support the PCCC protocol on a separate IP address. The PCCC protocol will allow the DH485 Router/B to emulate a legacy controller (e.g. SLC5/03) as if it is directly connected to the Ethernet network. Up to three PCCC IP Addresses with matching DH485 Target Addresses can be configured.</p>
Node & PCCC IP Address	<p><b>When using PCCC Direct</b>, the Node and PCCC IP Address allows the user to force the destination address of the DH485 message for each specific IP address which is routed via the PCCC protocol. This is useful when using certain RSLinx Enterprise drivers in FTView which does not allow the user to choose the destination DH485 Node address.</p> <p><b>NOTE: The three IP addresses will only be able to communicate using PCCC.</b></p> <p>For further information regarding this see the <i>FTView application notes</i> on the DH485 Router/B webpage.</p>
PCCC Node	<p><b>When not using PCCC Direct</b>, the PCCC Node allows the user to force the destination address of the DH485 message which is routed via the CIP embedded PCCC message. This is useful when using certain RSLinx Enterprise drivers in FTView which does not allow the user to choose the destination DH485 Node address.</p> <p>For further information regarding this see the <i>FTView application notes</i> on the DH485 Router/B webpage.</p>
Logix Connection	<p>The connection class used by the mapped items to the Logix controller.</p>

Table 3.4 - Transparent Map parameters

## 3.6.1.1. TRANSPARENT MODE - REMOTE PROGRAMMING

The remote example, (illustrated below,) allows a remote DH485 device (SLC500) to be programmed via a DH485 Router/B across an Ethernet network. Refer to the Technical Application Note for RSLogix 500 programming using the DH485 Router/B for more information.

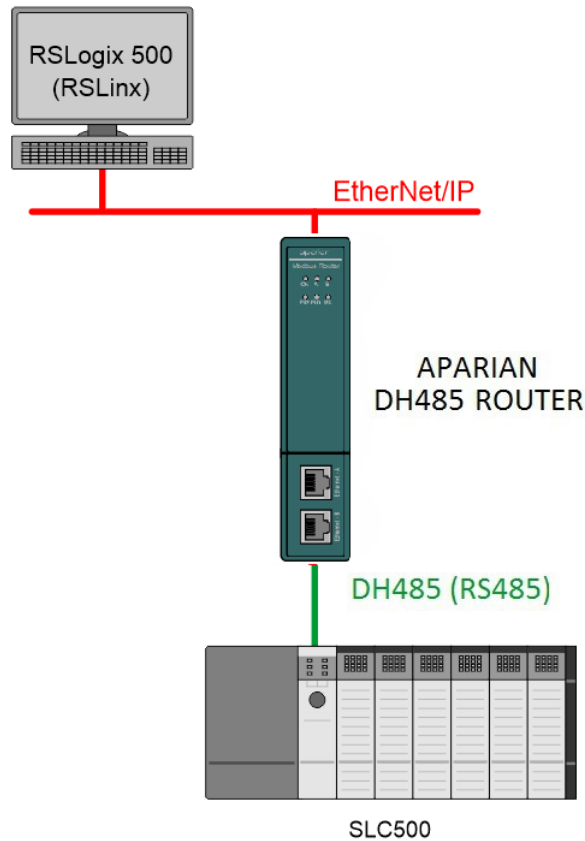

Figure 3.23. – Remote Programming Example



**NOTE:** At least one transparent mapped item must be added for the SLC500 programming to work on DH485. If the DH485 Router/B is used purely for programming, then the user can add a DH485 node of zero with an IP address matching the local PC running RSLogix 500 (see below). The reason for this is because the DH485 Router/B requires a node on the network.

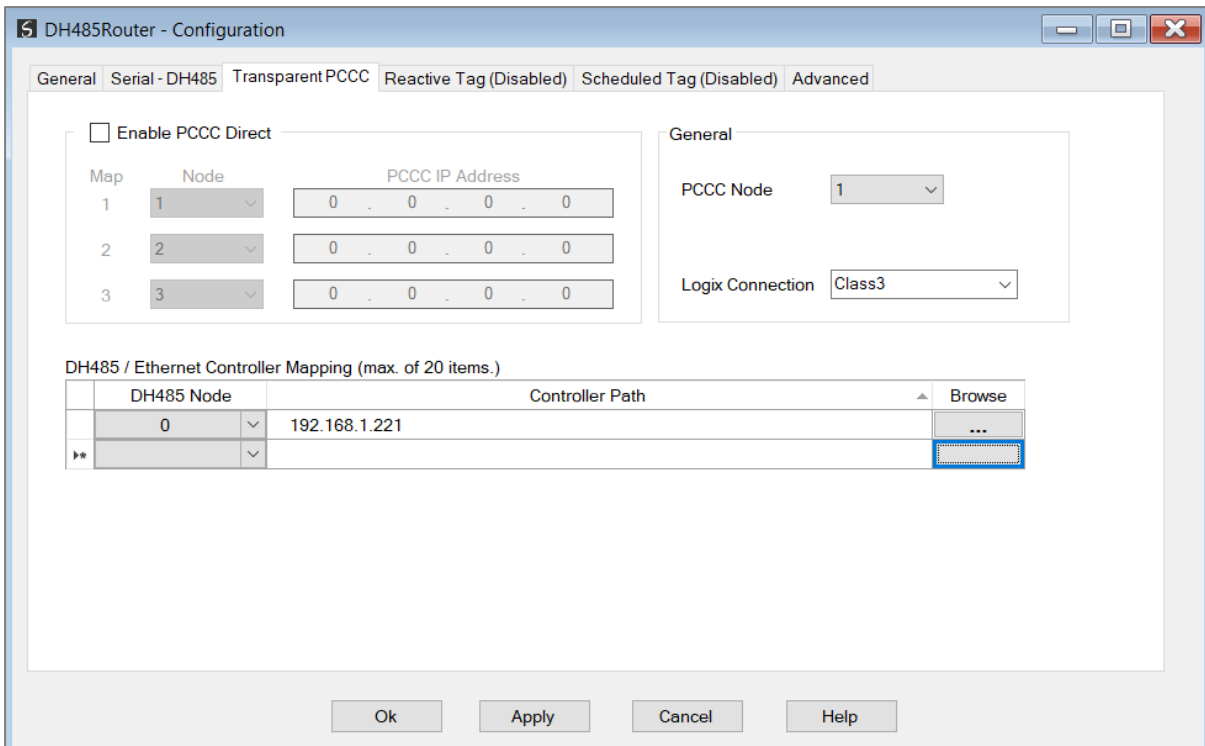

Figure 3.24 – Mapping required if no other mapping exists for RSLogix500 programming

To enable RSLinx to scan the DH485 network the DH485 Router/B must be setup correctly. This is achieved by right-clicking on the DH485 Port in RSLinx and selecting properties.

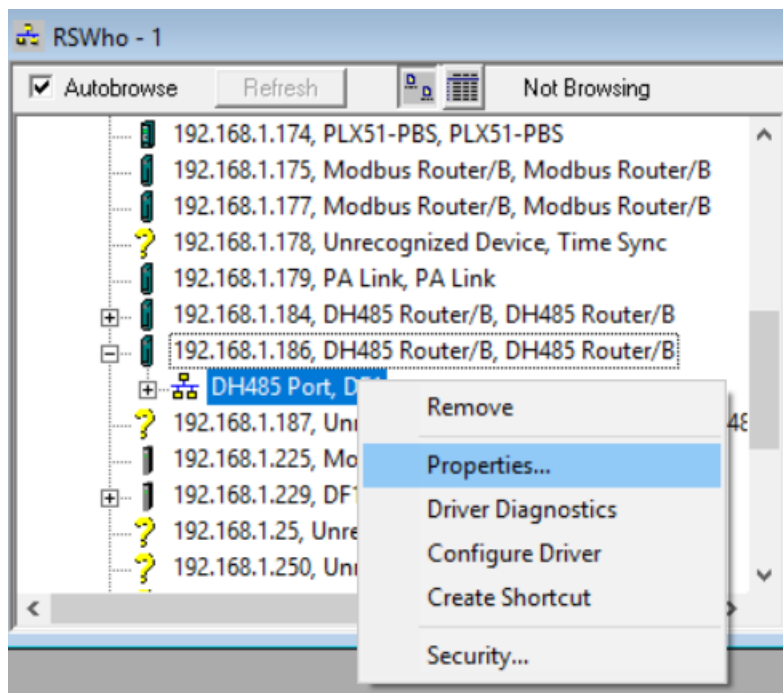

Figure 3.25 – Set DH485 network properties

Next the user will need to set the scan range.

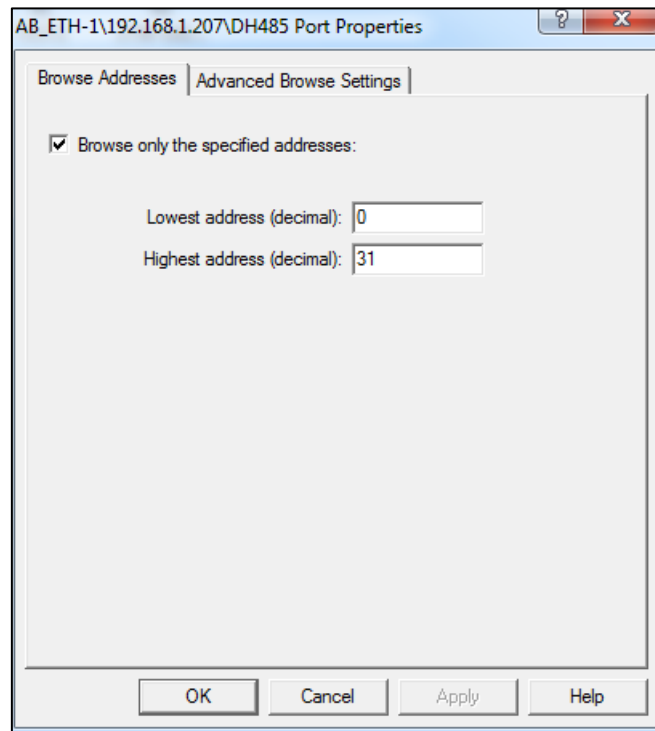

Figure 3.26 – Set Browse range

The select the *Advanced Browse Settings* and set the *Maximum Concurrent Packets* to 5.

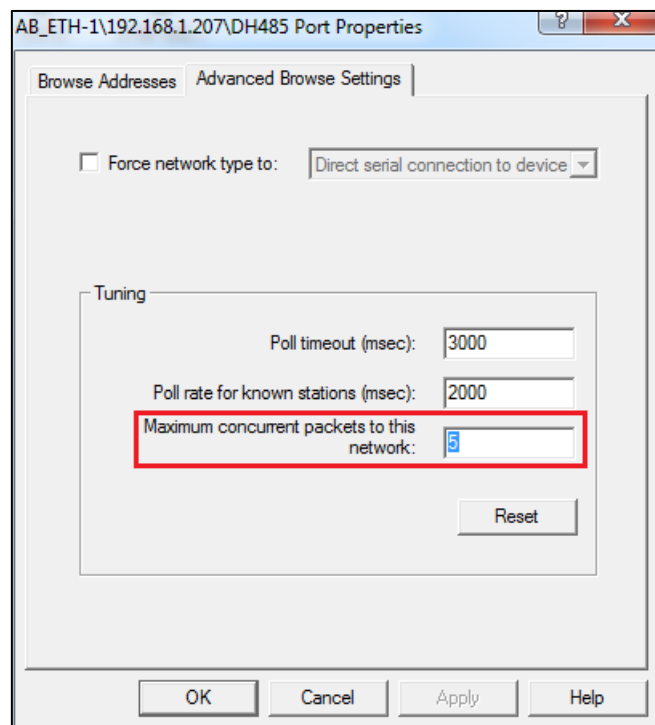

Figure 3.27 – Set maximum concurrent packets

The user can then select the DH485 Port on the DH485 Router/B and it will scan the DH485 network for devices. These devices can be selected from RSLogix 500 as target devices used for programming the SLC/MicroLogix controllers.

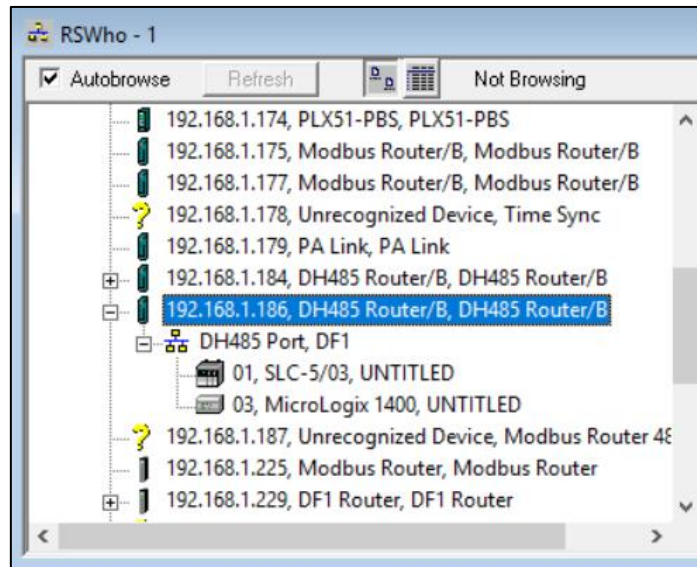

Figure 3.28 – Remote Programming Example – RSLinx RSWWho browser



**NOTE:** When having multiple DH485 Router/Bs on the same DH485 network and the user wants to browse the DH485 network via RSLinx, the user must ensure that all the DH485 Router/Bs on the network have been configured for PCCC operation. Failing to do this will result in incorrect scanning behaviour.



**NOTE:** When having multiple DH485 Router/Bs on the same DH485 network the DH485 Router/B used for scanning could find the Logix controllers mapped to the other DH485 Router/Bs (as shown below). It is normal for these Logix controllers to appear and disappear from the network as certain RSLinx routed messages for Logix controllers are **not** supported by the DH485 network.

#### 3.6.1.2. TRANSPARENT MODE – DATA MAPPING

In transparent mode, the DH485 Router/B will redirect a DH485 PCCC message to a Logix controller at a preconfigured path. Therefore, in this mode, the module will rely on the Logix controller to map the DH485 request to the preconfigured Logix tag.

The transparent map configuration is a two-step process. First the DH485 Router/B must be configured to route specific DH485 addresses to a controller path. The second step is to map the DH485 addresses to Logix tags using RSLogix 5000 / Studio 5000.

The DH485 message initiator (e.g. SLC Controller) will send a read or write request to a specific DH485 address on DH485. The user must configure the DH485 Router/B to route the message destined for a specific DH485 address to a Logix controller. This will allow the correct Logix controller to map the request to the Logix PLC/SLC mapped tag. For each route map the user must enter two parameters as described in the table below.

Below are two examples of how DH485 messages are routed to the Logix controller.

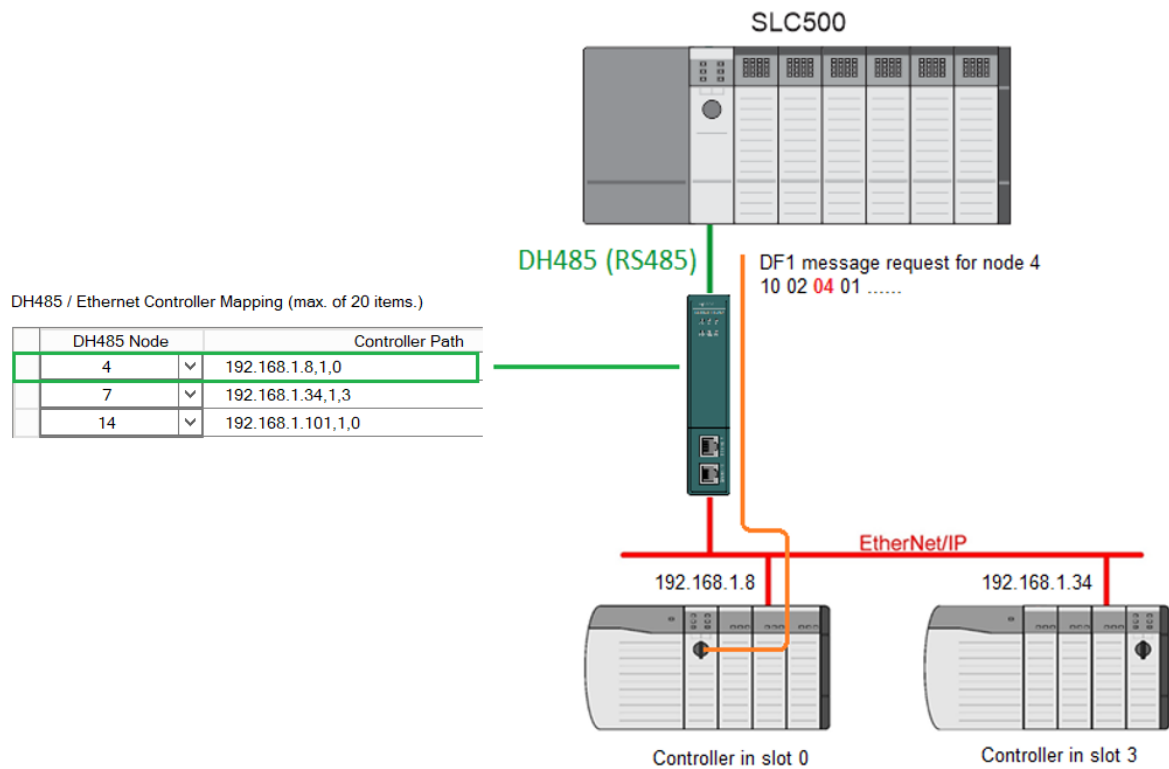

Figure 3.29 – Example 1 - Transparent routing map – node 4

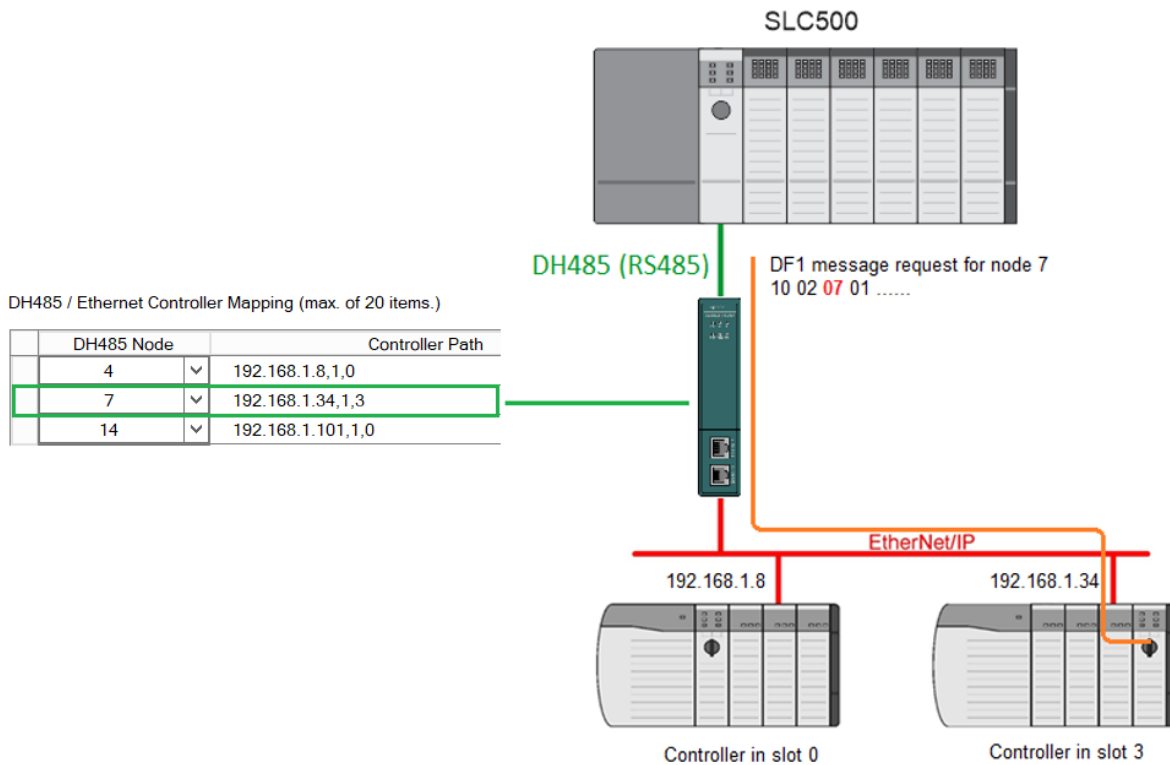

Figure 3.30 – Example 2 – Transparent routing map – node 7

The second part of the transparent routing map setup is to map the DH485 request received by the Logix controller to a Logix tag. This must be done in Rockwell Automation’s RSLogix 5000 or Studio 5000 Logix Designer environments. Refer to the additional information section in this document for further information regarding mapping of PLC/SLC messages in the Logix controller. Open the mapping table in RSLogix 5000 by selecting *Map PLC/SLC Messages* from the *Logic* menu item in the menu bar. The user must enter the requested file number and Logix tag name pair to ensure that the read or write request is routed to the correct Logix tag. Below is an example of the RSLogix 5000 PLC5/SLC mapping.

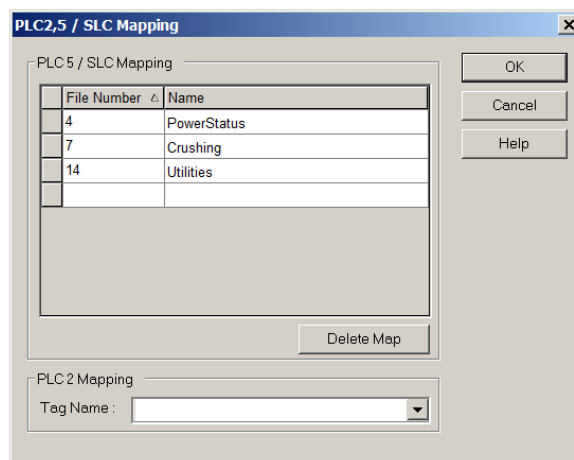

Figure 3.31 - Example of Mapping PLC/SLC Messages in RSLogix 5000



**NOTE:** It is the user's responsibility to ensure that the Logix tag array datatype and size matches that of the DH485 File Number. Failing to do this can result in communication faults.

### 3.6.2. REACTIVE TAG MODE

The Reactive Tag routing mode allows mapping of virtual Data Files to Logix tags across multiple controllers. This is similar to the Transparent PCCC mode except the mapping of data files to Logix tags, is no longer managed in Logix, but in the DH485 Router/B itself.

In this mode the routing of the Node address to Logix controller as well as the mapping of a DH485 File Number to a Logix tag is managed by the DH485 Router/B.

In the Reactive Tag mode, the DH485 Router/B can operate completely independently from the Logix controller by directly reading and writing to Logix tags.



**NOTE:** The Reactive Tag mode will only work with PLC5, SLC Typed Read and

DH485Router - Configuration

General Serial - DH485 Transparent PCCC (Disabled) **Reactive Tag** Scheduled Tag (Disabled)

Logix Controller Mapping (max. of 8 items.)

	Target Name	Logix Controller Path	Browse
	NorthCPU	192.168.1.34,1,3	...
>*			

Logix Tag Mapping (max. of 20 items.)

	DH485 Node	Data File	Target Name	Target Tag	Browse
*					

Ok Apply Cancel

Figure 3.32 - Reactive Tag mode configuration

The Reactive Tag mode is configured in two steps. First the user must create a Target Name (CIP path to the destination Logix controller) which will be used to link the DH485 File Number to the destination Logix tag.



The Logix controller paths can either be entered manually or the user can browse to them by clicking the Browse button. The Target Browser will open and automatically scan for all available EtherNet/IP devices.

If the Ethernet/IP module is a bridge module, it can be expanded by right-clicking on the module and selecting the **Scan** option.

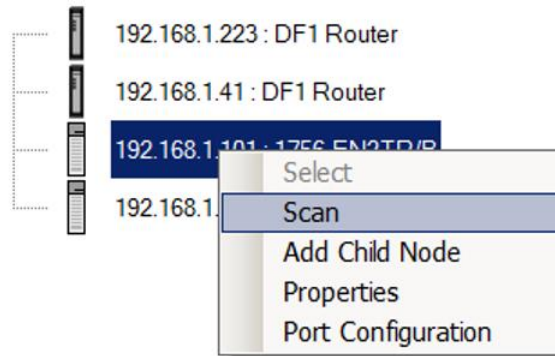

Figure 3.33 - Scanning node in the Target Browser

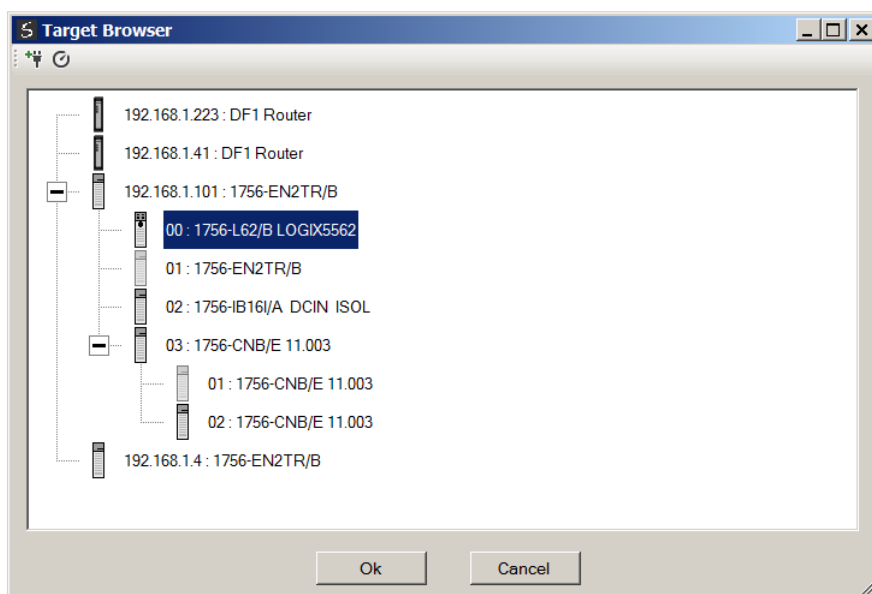

Figure 3.34 - Target Browser selection

The required Logix controller can then be chosen by selecting it and clicking the **Ok** button, or by double-clicking on the controller module.

A maximum number of 8 controller mapping entries can be added.

The second part of the Reactive Tag mode is to configure the link between a DH485 node and File Number combination to a Logix tag. This will allow the DH485 message initiator to effectively write to, or read from, a Logix tag using traditional File Numbers (e.g. N7, F8, etc.).

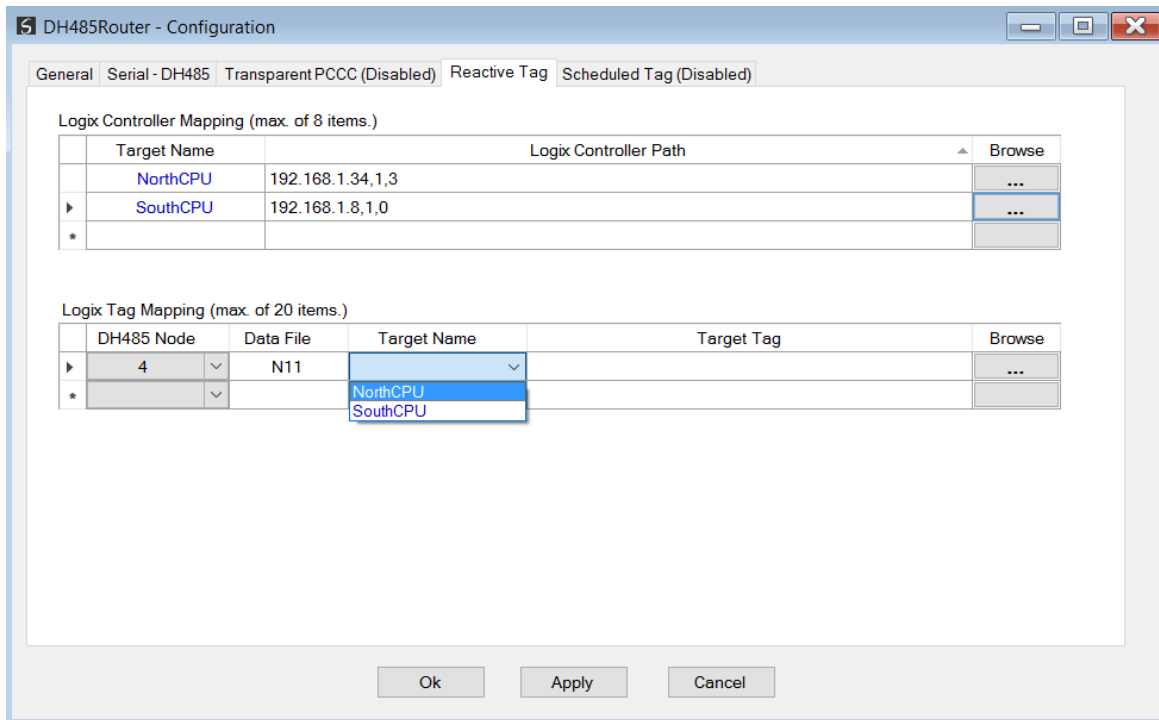

Figure 3.35 – Reactive Tag Mapping

The module can emulate more than one destination DH485 Node Address, and thus route multiple messages to different Logix controllers. For this reason, it is important to enter the correct associate DH485 Node address in each mapping record.

The next column is used to enter the **Data File**. It is important to enter only the file here (e.g. N11) and not a data word address (e.g. N11:0). The first element of the entered data file (e.g. N11:0) will then map to the first element of the Logix array and so on.

Below is an example of the target tag selection. The Target Tag can be either entered manually or selected using the Tag Browser in Slate. The Tag Browser requires the controller to be available on the network.

To browse to the tag, click on the **Browse** button. The Tag Browser will open and scan all the tags inside that controller. If the controller has been recently scanned in this Slate session, then a cached version of the tags will be displayed. A rescan of the tags can be triggered by selecting the **Refresh** button in the Tag Browser's toolbar.

All the non-array tags will be disabled, guiding the user to select a suitable tag.



**NOTE:** When mapping PLC5 Boolean files (e.g. B3) it is recommended that the destination Logix tag be a SINT array, rather than a Boolean array. Using the latter may result in unexpected results due to the packing format of Logix Boolean arrays.

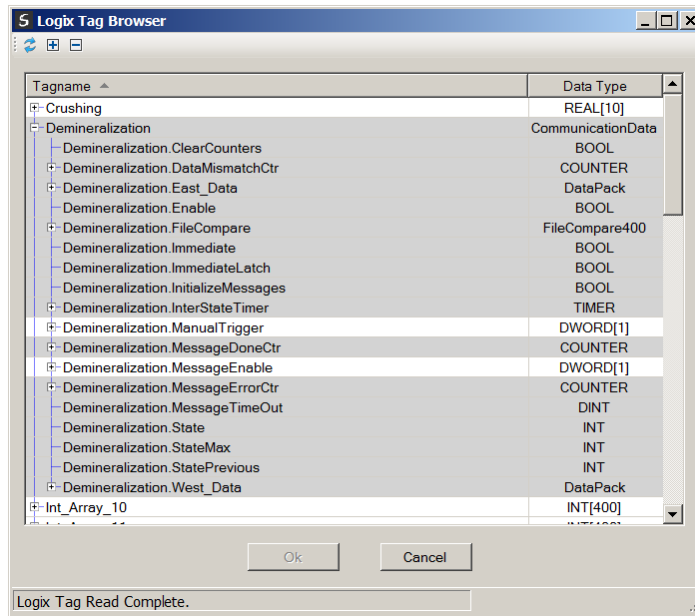

Figure 3.36 – Tag Browser tag selection

The figure below illustrates how DH485 messages are routed to the Logix tags using the Reactive Tag Map mode.



**NOTE:** It is the user’s responsibility to ensure that the Logix tag array datatype and size matches that of the Data File Number. Failing to do this can result in communication faults.

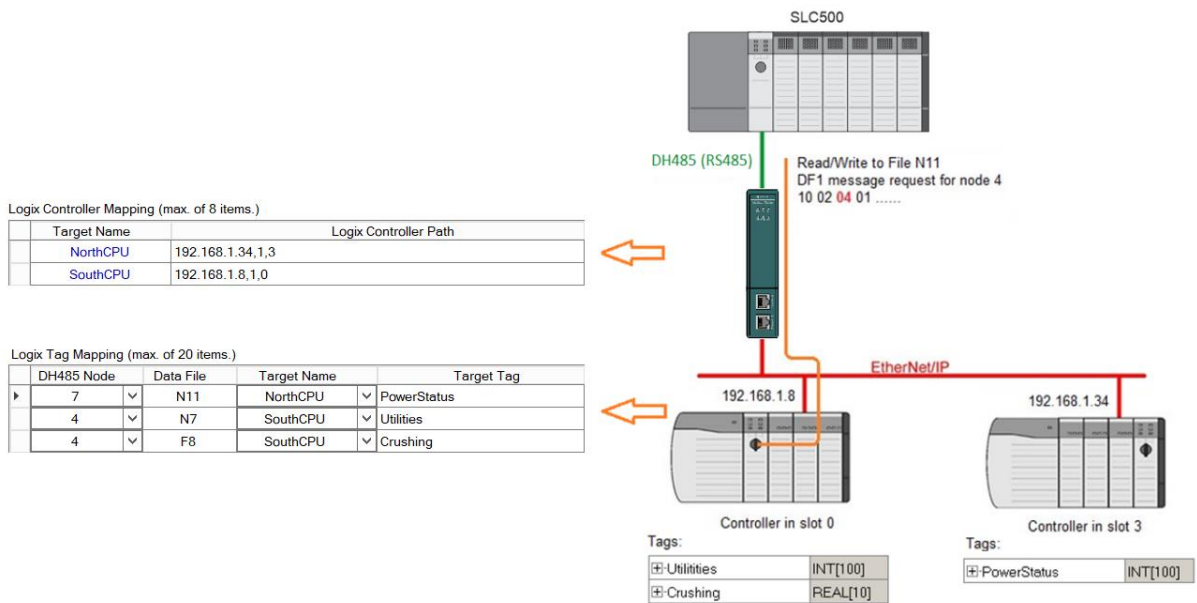

Figure 3.37 - Reactive Tag mode configuration in Slate

### 3.6.3. SCHEDULED TAG MODE

The Scheduled Tag routing mode transfers data between a DH485 device and one or more Logix controllers. Unlike the Transparent and Reactive tag mode, the DH485 Router/B when in the Scheduled Tag mode initiates the messaging.

In this mode the DH485 Router/B transfers data between a Logix controller and a DH485 device without any configuration or programming required in either the DH485 device or the Logix controller.

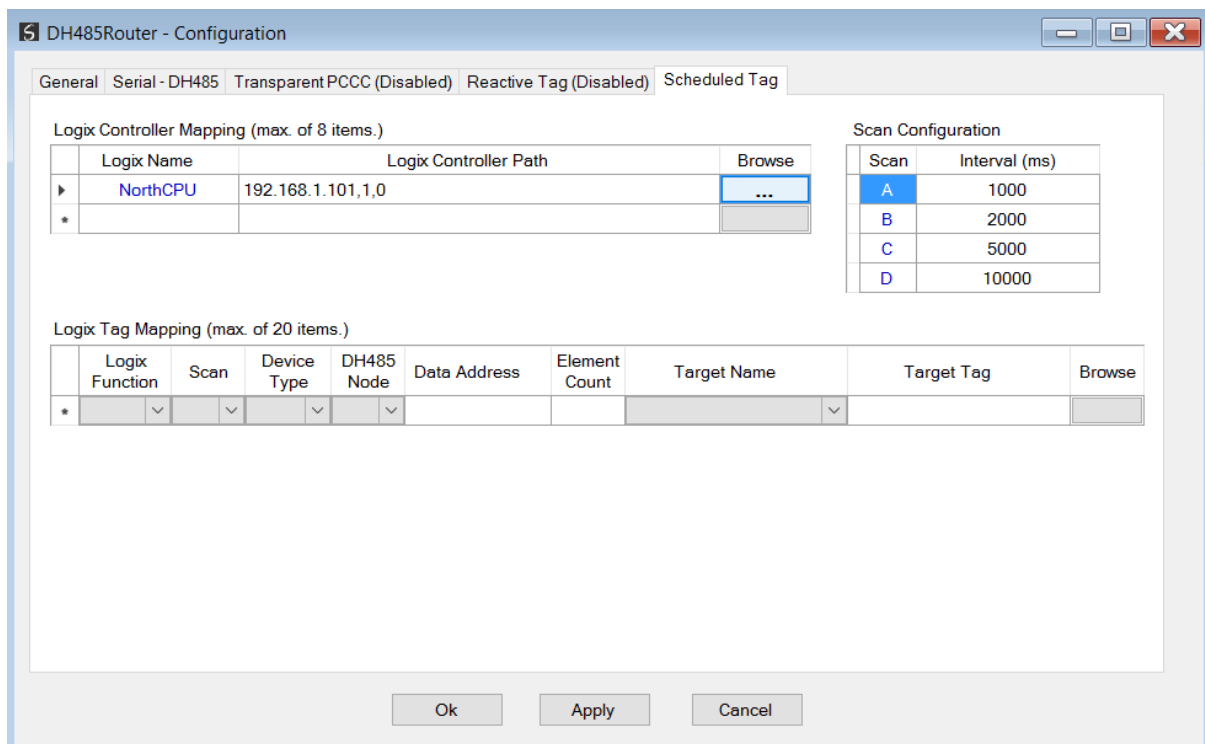

Figure 3.38 - Scheduled Tag configuration

The Schedule Tag mode is configured in three steps:

First the user must create a Target Name (CIP path to the destination Logix controller) which will be used to link the Data File Number to the destination Logix tag.

The Logix controller paths can either be entered manually or the user can browse to them by clicking the **Browse** button. The Target Browser will open and automatically scan for all available EtherNet/IP devices.

If the Ethernet/IP module is a bridge module, it can be expanded by right-clicking on the module and selecting the **Scan** option.

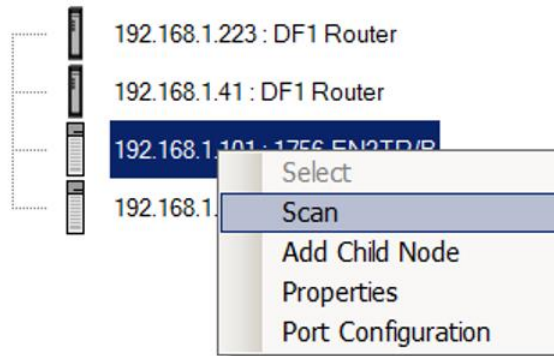

Figure 3.39 - Scanning node in the Target Browser

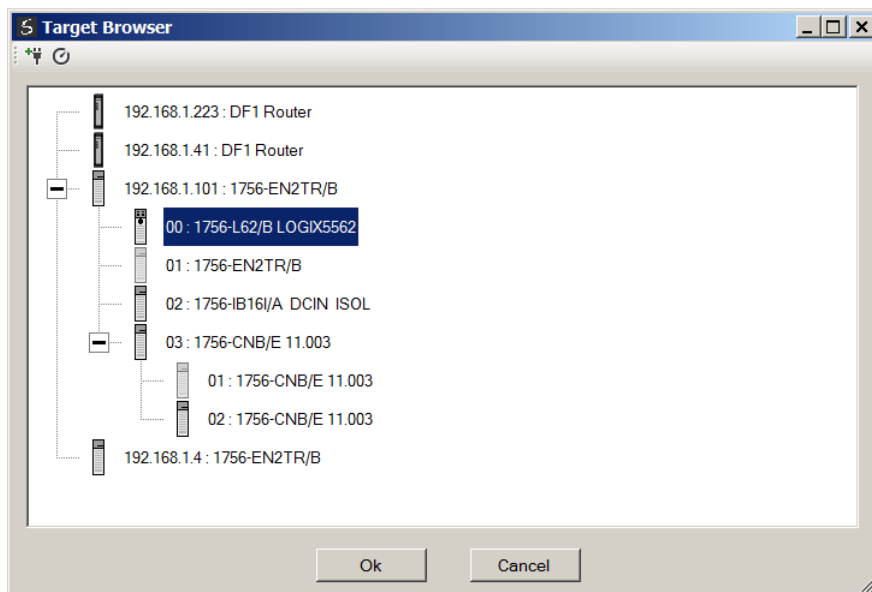

Figure 3.40 - Target Browser selection

The required Logix controller can then be chosen by selecting it and clicking the **Ok** button, or by double-clicking on the controller module.

A maximum number of 8 controller mapping entries can be added.

The second part of the Scheduled Tag mode setup is to configure the scan intervals. The scan intervals allow different data items to be transferred at different rates. There are 4 scan classes, viz. A, B, C and D. The intervals for each can be adjusted by entering the scan time in milliseconds. The interval must be between 200 milliseconds and 60 seconds.

The third part of the Scheduled Tag mode setup is to configure the link between a DH485 node and Data File Number combination to a Logix tag, and the associated action and scan required.

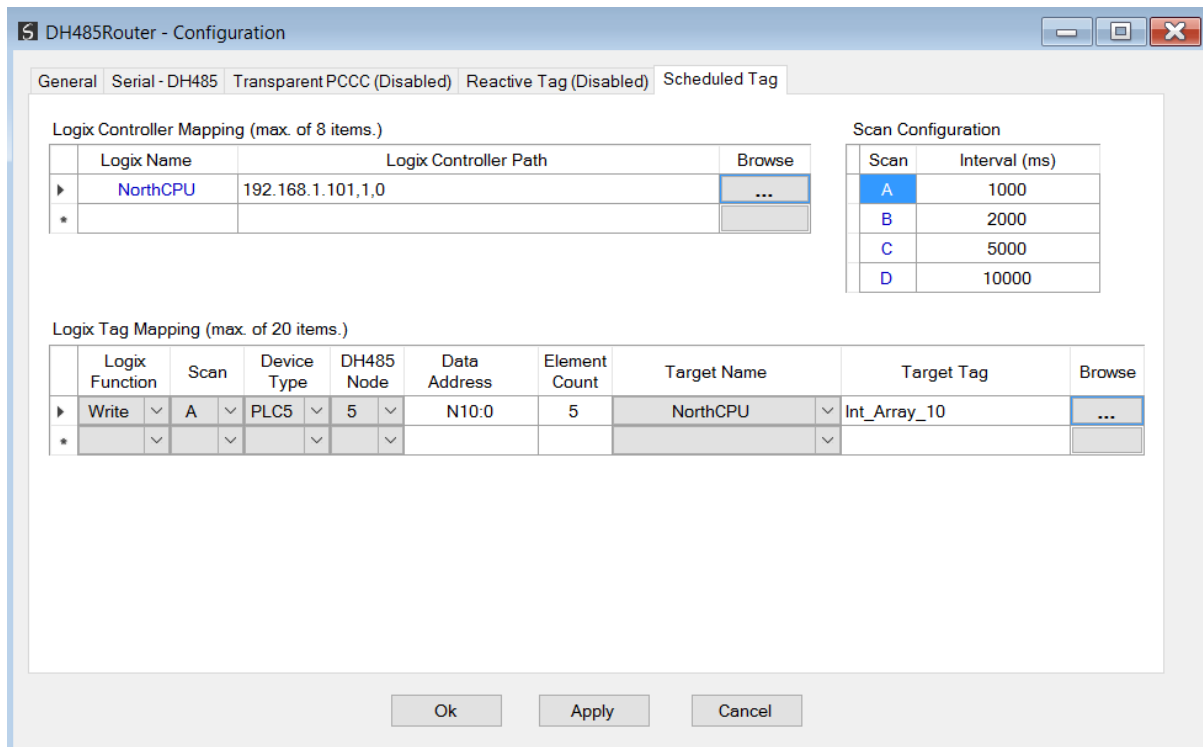

Figure 3.41 - Scheduled Tag Mapping

The Logix Function field specifies whether the transaction will result in a read or write from the Logix controller's perspective.

The Scan field specifies at what rate the transaction will be executed. Select a scan class letter that matches the required interval. Care must be taken to select a realistic scan interval, taking into account the configured Baud rate and message size.

The Device Type field specifies the type of message that will be sent to the DH485 device. There are two options, PLC5 and SLC. The latter should be selected when using a MicroLogix device.

The DH485 Node is the remote device's DH485 node address.

The Data Address is the remote device's address and should be specified to the element level. For example, N10:0. (Note that this differs from the Reactive Tag configuration where only the file is specified.)

The Element Count is the number of items to be read or written. In the example above, with a Data Address of N10:0 and an Element Count of 5, then N10:0 through N10:4 will read from the DH485 device and written to Logix.

One of the Target Names configured in the first step can be selected by means of the target Name combo box.

The Target Tag can be either entered manually or selected using the Tag Browser in Slate. The Tag Browser requires the controller to be available on the network.

To browse to the tag, click on the **Browse** button. The Tag Browser will open and scan all the tags inside that controller. If the controller has been recently scanned in this Slate session, then a cached version of the tags will be displayed. A rescan of the tags can be triggered by selecting the Refresh button in the Tag Browser's toolbar.

Only tags of a relevant type will be enabled, guiding the user to select a suitable tag.



**NOTE:** When mapping PLC5 Boolean files (e.g. B3) it is recommended that the destination Logix tag be a SINT array, rather than a Boolean array. Using the latter may result in unexpected results due to the packing format of Logix Boolean arrays.

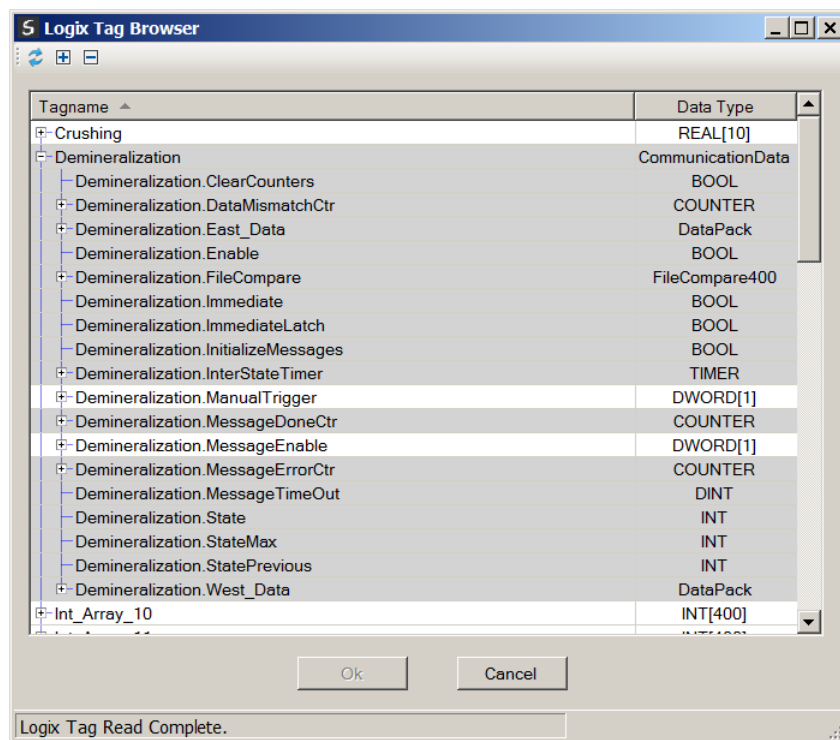

Figure 3.42 - Tag Browser tag selection



**NOTE:** It is the user's responsibility to ensure that the Logix tag array datatype and size matches that of the selected Data Address. Failing to do this can result in communication faults and unexpected results.

### 3.6.4. UNSCHEDULED MODE

There is no additional configuration required when using the Unscheduled Mode. The configuration required for the DH485 message is contained within the Message Block data, configured in Logix.

### 3.6.5. AIC MODE

There is no additional configuration required when using the AIC Mode.

In AIC mode the DH485 Router/B routes has no intelligent routing, but only translates the requests from the DH485 network to RS232 and vice versa. This mode provides the functionality for the DH485 Router/B to emulate the legacy NET-AIC module.

## 3.7. MODULE DOWNLOAD

Once the DH485 configuration has been completed, it must be downloaded to the module. Before downloading the Connection Path of the module should be set. This path will automatically default to the IP address of the module, as set in the module configuration. It can however be modified, if the DH485 Router/B is not on a local network.

The Connection path can be set by right-clicking on the module and selecting the **Connection Path** option.

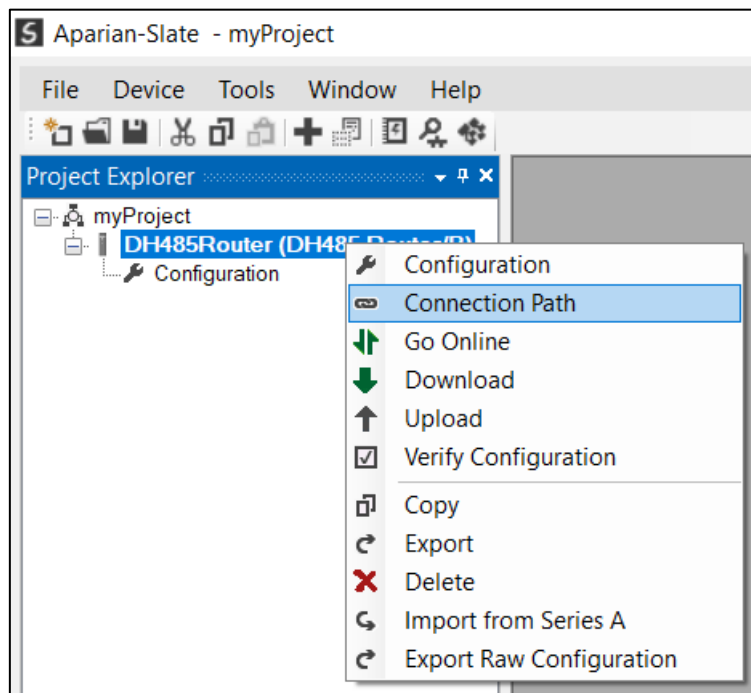

Figure 3.43 - Selecting Connection Path



The new connection path can then be either entered manually or selected by means of the Target Browser.

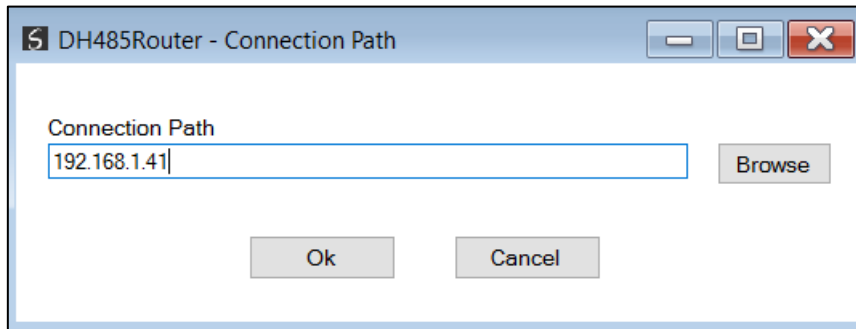

Figure 3.44 - Connection Path

To initiate the download, right-click on the module and select the Download option.

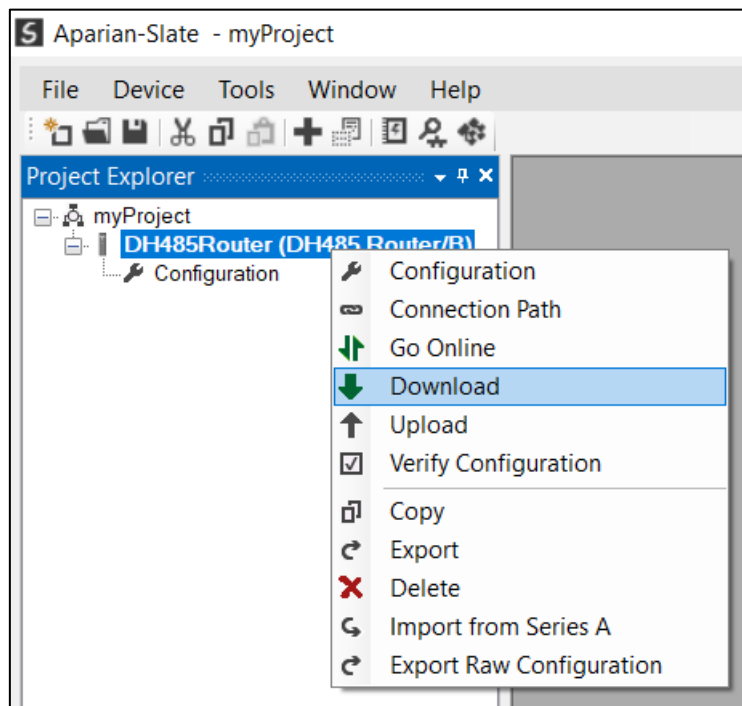

Figure 3.45 - Selecting Download

Once complete, the user will be notified that the download was successful.

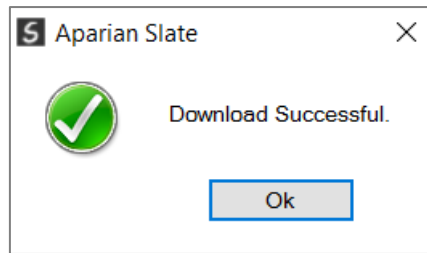

Figure 3.46 - Successful download

Within the Slate environment the module will be in the Online state, indicated by the green circle around the module. The module is now configured and will start operating immediately.

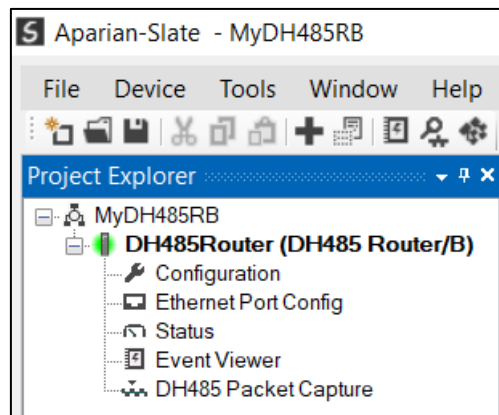

Figure 3.47 - Module online

## 3.8. RSLOGIX 5000 CONFIGURATION

The DH485 Router/B modules can be easily integrated with Allen-Bradley Logix family of controllers.

### 3.8.1. ADD MODULE TO I/O CONFIGURATION

The module can operate in both a Logix “owned” and standalone mode. When the module operates in a Logix “owned” mode the DH485 Router/B will need to be added to the RSLogix 5000 IO tree. The module will need to be added as a generic Ethernet module. This is done by right clicking on the Ethernet Bridge in the RSLogix/Studio 5000 and selecting **New Module** after which the **ETHERNET-MODULE** is selected to be added as shown in the figure below.



NOTE: See the next section for importing the configuration (L5X).

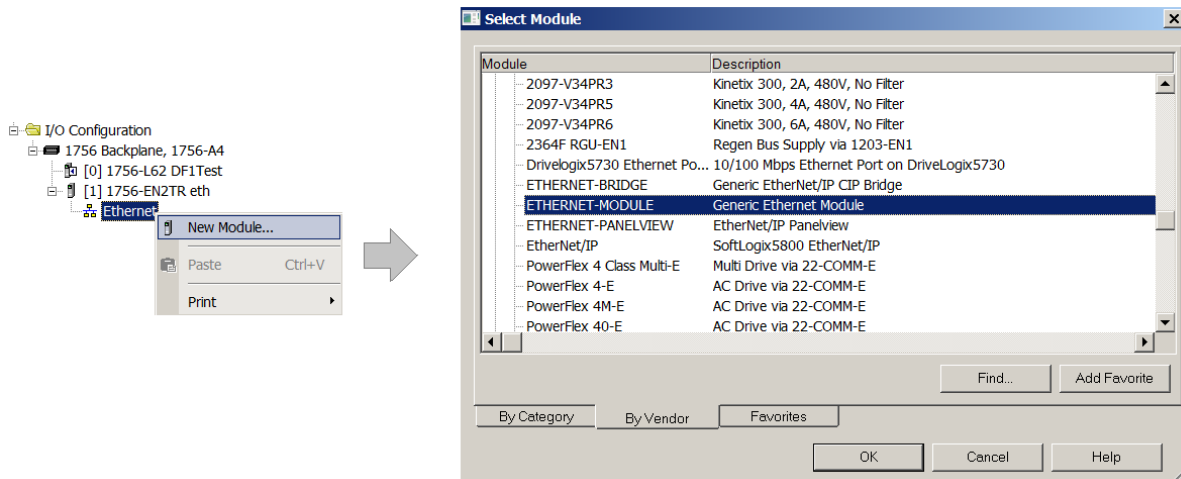

Figure 3.48 - Add a Generic Ethernet Module in RSLogix 5000

The user must enter the IP address of the DH485 Router/B that will be used. The assembly instance and size must also be added for the input, output, and configuration in the connection parameters section. Below are the required connection parameters.

Connection Parameter	Assembly Instance	Size
Input	100	34 (32-bit)
Output	101	1 (32-bit)
Configuration	102	0 (8-bit)

Table 3.5 - RSLogix class 1 connection parameters for the DH485 Router/B

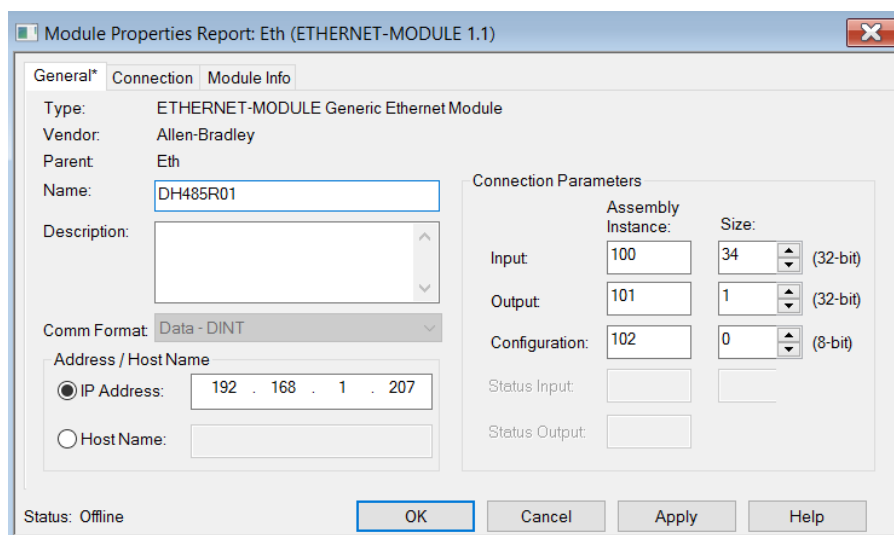

Figure 3.49 - RSLogix General module properties in RSLogix 5000



**NOTE:** The user will need to enter the exact connection parameters before the module will establish a class 1 connection with the Logix controller.

Next the user needs to add the connection requested packet interval (RPI). This is the rate at which the input and output assemblies are exchanged. The recommended value is 500ms. Refer to the technical specification section in this document for further details on the limits of the RPI.



**NOTE:** Although the module is capable of running with an RPI of 10ms, it is recommended to set the RPI to 500ms, to avoid unnecessary loading of the module processor.

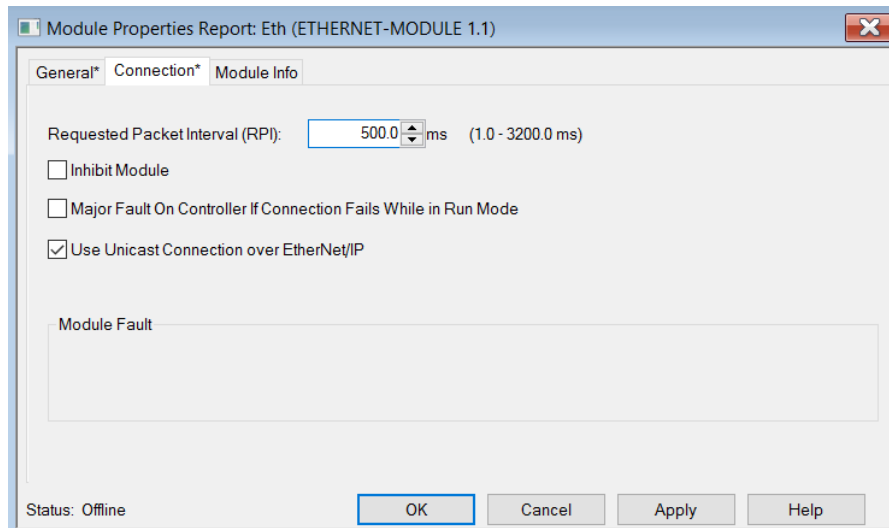

Figure 3.50 - Connection module properties in RSLogix 5000

Once the module has been added to the RSLogix 5000 IO tree the user must assign the User Defined Types (UDTs) to the input and output assemblies. The user can import the required UDTs by right-clicking on *User-Defined* sub-folder in the *Data Types* folder of the IO tree and selecting *Import Data Type*. The assemblies are then assigned to the UDTs with a ladder copy instruction (COP) as shown in the figure below.

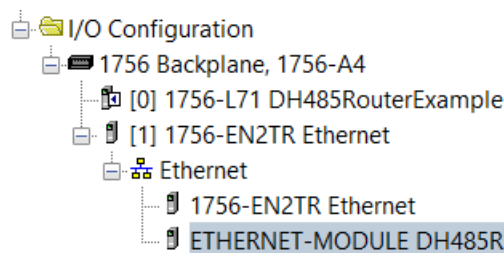

Figure 3.51 - RSLogix 5000 I/O module tree

### 3.8.2. IMPORTING UDTs AND MAPPING ROUTINES

To simplify the mapping of the input image, an RSLogix 5000 Routine Partial Import (L5X) file is provided.

This file can be imported by right-clicking on the required Program and selecting the Import Routine option.

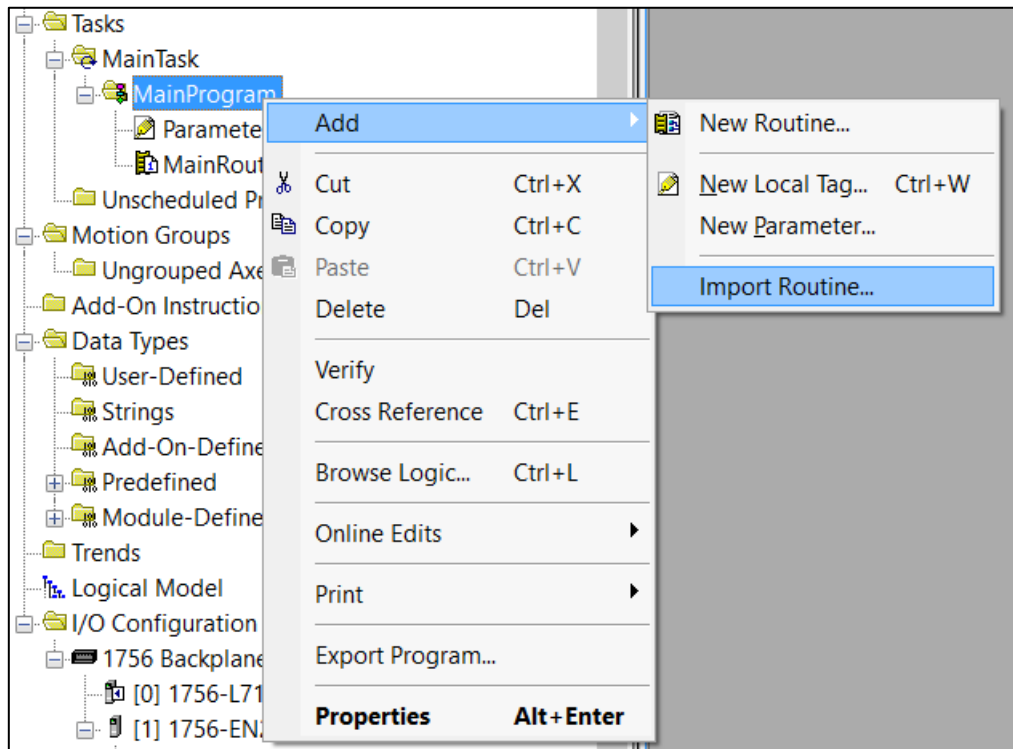

Figure 3.52 - RSLogix 5000 Importing DH485Router specific routine and UDTs

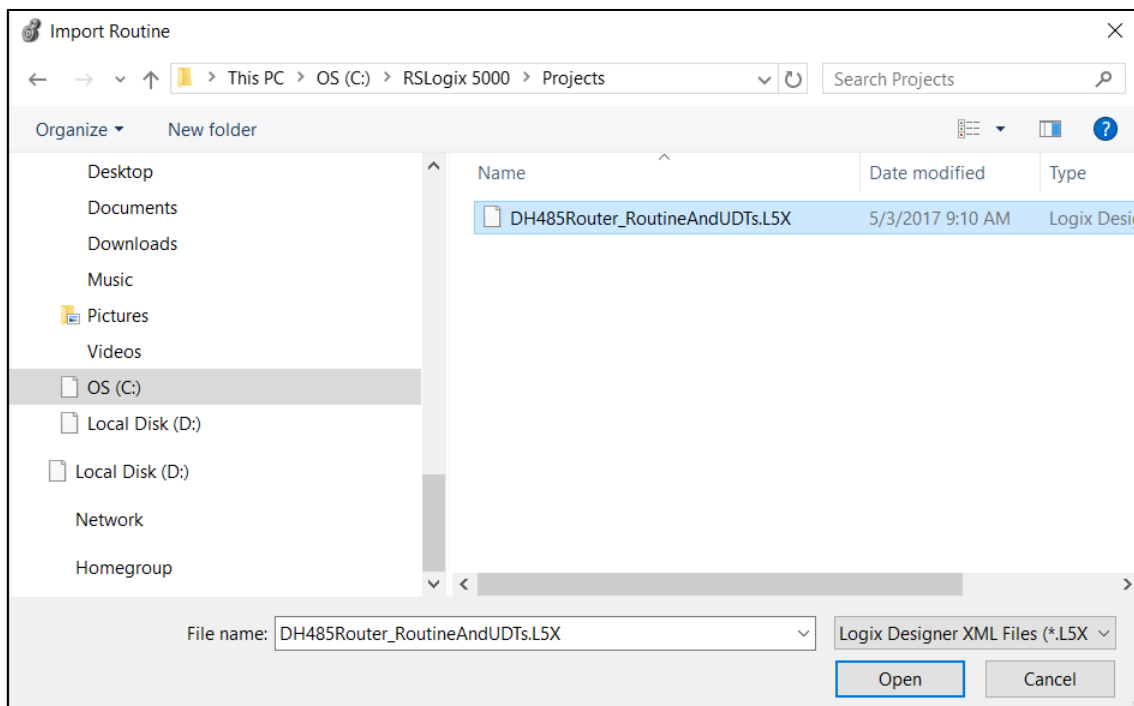

Figure 3.53 - Selecting partial import file

The import will create the following:

- The required UDTs (user defined data types)
- Two controller tags representing the Input and Output assemblies.
- A routine mapping the DH485Router module to the aforementioned tags.
- An example Unscheduled Message instruction with the associated Tags

The user may need to change the routine to map to the correct DH485 Router/B module instance name, and make sure that the mapping routine is called by the Program's Main Routine.

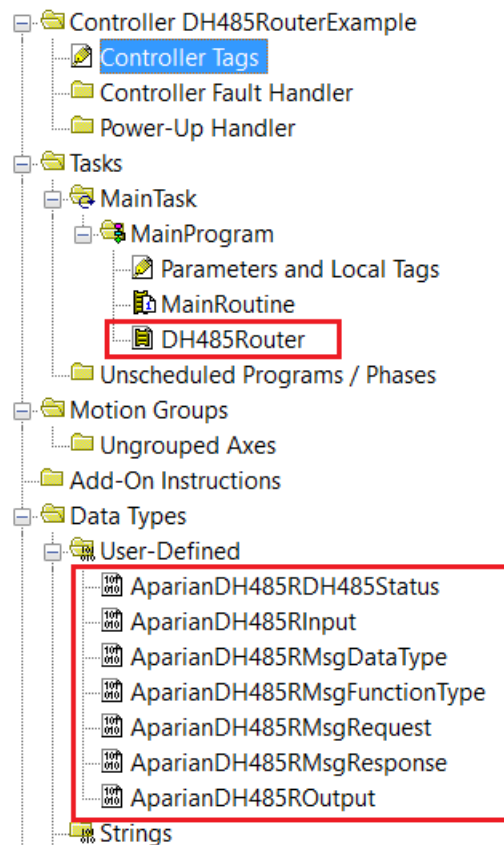

Figure 3.54 - Imported RSLogix 5000 objects

Refer to the additional information section of this document for an example RSLogix 5000 project as well as the required UDTs.

## 4. OPERATION

### 4.1. MESSAGE ROUTING

When the module has been correctly configured the DH485 message initiator will send a read/write command to a certain DH485 address which will then be routed to a Logix tag. The messages sent by the initiator must be valid for successful operation. There are various indicators to determine if the mapping is routing the DH485 messages correctly. Refer to the diagnostics section of this document for a more detailed explanation of the various indicators that can be used to diagnose the module.

### 4.2. RSLOGIX 5000 ASSEMBLIES

When the module operates in a Logix “owned” mode the Logix controller will establish a class 1 cyclic communication connection with the DH485 Router/B. An input and output assembly is exchanged at a fix interval. The UDTs provided will convert the input and output arrays into tag-based assemblies. Refer to the additional information section in this document for the input and output UDTs.

[-] DH485R01Input	{...}	{..		AparianDH485RInput
[-] DH485R01Input.Instance	'South'	{..		STRING
[-] DH485R01Input.Status	{...}	{..		AparianDH485RDH485Status
[-] DH485R01Input.Status.TransparentPCCCMODE	0		Decimal	BOOL
[-] DH485R01Input.Status.ReactiveTagMode	1		Decimal	BOOL
[-] DH485R01Input.Status.ScheduledTagMode	0		Decimal	BOOL
[-] DH485R01Input.Status.UnscheduledMode	0		Decimal	BOOL
[-] DH485R01Input.Status.ConfigurationValid	1		Decimal	BOOL
[-] DH485R01Input.Status.RoutingInhibited	0		Decimal	BOOL
[-] DH485R01Input.Status.Reserved1	0		Decimal	BOOL
[-] DH485R01Input.Status.Reserved2	0		Decimal	BOOL
[-] DH485R01Input.Status.ScheduledTagStatus0	0		Decimal	BOOL
[-] DH485R01Input.Status.ScheduledTagStatus1	0		Decimal	BOOL
[-] DH485R01Input.Status.ScheduledTagStatus2	0		Decimal	BOOL
[-] DH485R01Input.Status.ScheduledTagStatus3	0		Decimal	BOOL
[-] DH485R01Input.Status.ScheduledTagStatus4	0		Decimal	BOOL
[-] DH485R01Input.Status.ScheduledTagStatus5	0		Decimal	BOOL
[-] DH485R01Input.Status.ScheduledTagStatus6	0		Decimal	BOOL
[-] DH485R01Input.Status.ScheduledTagStatus7	0		Decimal	BOOL
[-] DH485R01Input.Status.ScheduledTagStatus8	0		Decimal	BOOL
[-] DH485R01Input.Status.ScheduledTagStatus9	0		Decimal	BOOL
[-] DH485R01Input.Status.ScheduledTagStatus10	0		Decimal	BOOL
[-] DH485R01Input.Status.ScheduledTagStatus11	0		Decimal	BOOL
[-] DH485R01Input.Status.ScheduledTagStatus12	0		Decimal	BOOL
[-] DH485R01Input.Status.ScheduledTagStatus13	0		Decimal	BOOL
[-] DH485R01Input.Status.ScheduledTagStatus14	0		Decimal	BOOL
[-] DH485R01Input.Status.ScheduledTagStatus15	0		Decimal	BOOL
[-] DH485R01Input.Status.ScheduledTagStatus16	0		Decimal	BOOL
[-] DH485R01Input.Status.ScheduledTagStatus17	0		Decimal	BOOL
[-] DH485R01Input.Status.ScheduledTagStatus18	0		Decimal	BOOL
[-] DH485R01Input.Status.ScheduledTagStatus19	0		Decimal	BOOL
[-] DH485R01Input.TransactionRate	31		Decimal	DINT
[-] DH485R01Input.Temperature	46.3		Float	REAL
[-] DH485R01Input.DH485RxPacketCount	34218		Decimal	DINT
[-] DH485R01Input.DH485TxPacketCount	34217		Decimal	DINT
[-] DH485R01Input.DH485ChecksumErrors	0		Decimal	DINT
[-] DH485R01Input.PCCCRequests	0		Decimal	DINT
[-] DH485R01Input.PCCCFailures	0		Decimal	DINT
[-] DH485R01Input.TagReads	16522		Decimal	DINT
[-] DH485R01Input.TagWrites	587		Decimal	DINT
[-] DH485R01Input.TagConnectionFailures	0		Decimal	DINT
[-] DH485R01Input.TagErrors	0		Decimal	DINT

Figure 4.1 – Input assembly UDT structure

### 4.2.1. INPUT ASSEMBLY

The following parameters are used in the input assembly of the module.

Parameter	Datatype	Description
Instance	STRING	This parameter is the instance name of the module that was configured under the general DH485 configuration in Slate.



Status.TransparentPCCCMoDe	BOOL	Set if the module is operating in Transparent PCCC mode.
Status.ReactiveTagMode	BOOL	Set if the module is operating in Reactive Tag mode.
Status.ScheduledTagMode	BOOL	Set if the module is operating in Scheduled Tag mode.
Status.UnscheduledMode	BOOL	Set if the module is operating in Unscheduled mode.
Status.ConfigurationValid	BOOL	Set if a valid configuration is executing in the module.
Status.RoutingInhibited	BOOL	Set when the module's routing function has been inhibited. Routing can be inhibited by setting a bit in the output assembly of the module.
Status.ScheduledTagStatus0...19	BOOL[20]	Each bit represents the status of the last scheduled transaction for that specific map item. A true value indicates success.
TransactionRate	DINT	The transaction rate is the number of DH485 messages per second that the module is currently routing.
DeviceTemperature	REAL	The internal temperature of the module.
DH485RxPacketCount	DINT	The total number of DH485 packets received by the module.
DH485TxPacketCount	DINT	The number of DH485 packets sent by the module.
DH485ChecksumErrors	DINT	The number of corrupted DH485 packets received by the module.
PCCCRequests	DINT	The total number of DH485 message routing requests received by the module when operating in Transparent mode.
PCCCFailures	DINT	The total number of DH485 message routing requests that resulted in errors when operating in Transparent mode.
TagReads	DINT	The total number of tag reads executed by the module when operating in Tag Map mode.
TagWrites	DINT	The total number of tag writes executed by the module when operating in Tag Map mode.
TagConnectionFailures	DINT	The number of failed class 3 connection attempts when operating in Tag Map mode. Tag reading and writing requires the module to first establish a class 3 connection with the Logix Controller.
TagErrors	DINT	The number of failed tag access (read/write) requests when operating in tag Map mode. These may include privileged violations, non-existing tags, etc.

Table 4.1 - RSLogix 5000 input assembly parameters

### 4.2.2. OUTPUT ASSEMBLY

The following parameters are used in the output assembly of the module.

Parameter	Datatype	Description
RoutingInhibit	BOOL	This bit inhibits the module routing capabilities. When set, no DH485 messages will be routed. This may be required in applications running a redundant DH485 network where one of the DH485 Router/Bs is to run in a hot-standby mode.

Table 4.2 - RSLogix 5000 output assembly parameters

### 4.3. UNSCHEDULED MESSAGING

When the DH485 Router/B is configured in Unscheduled Mode, it will process DH485 message requests sent from Logix via a message instruction.

To simplify the configuration of the required, message several UDTs have been preconfigured, and are available on the Aparian DH485Router webpage.

The message instruction should be setup as follows:

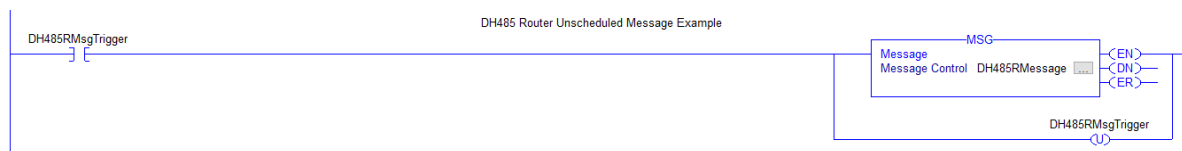

Figure 4.2. - Message Instruction

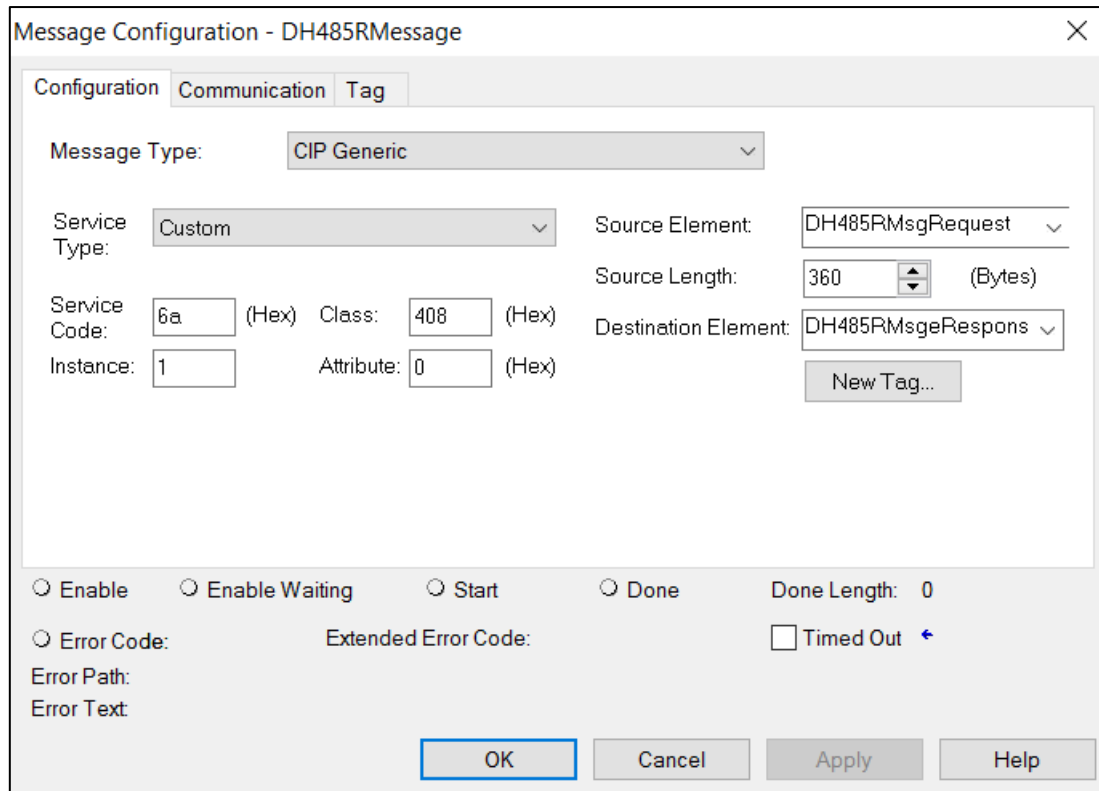

Figure 4.3. - Message Configuration

Parameter	Description
Message Type	CIP Generic
Service Type	Custom
Service Code	6A (Hex) - Unscheduled DH485 Pass-through
Class	408 (Hex)
Instance	1
Attribute	0
Source Element	The request tag instance. Must follow the structure of the AarianDH485RMsgRequest UDT.
Source Length	360
Destination Element	The response tag instance. Must follow the structure of the AarianDH485RMsgResponse UDT.

Table 4.3. - Message Configuration Parameters

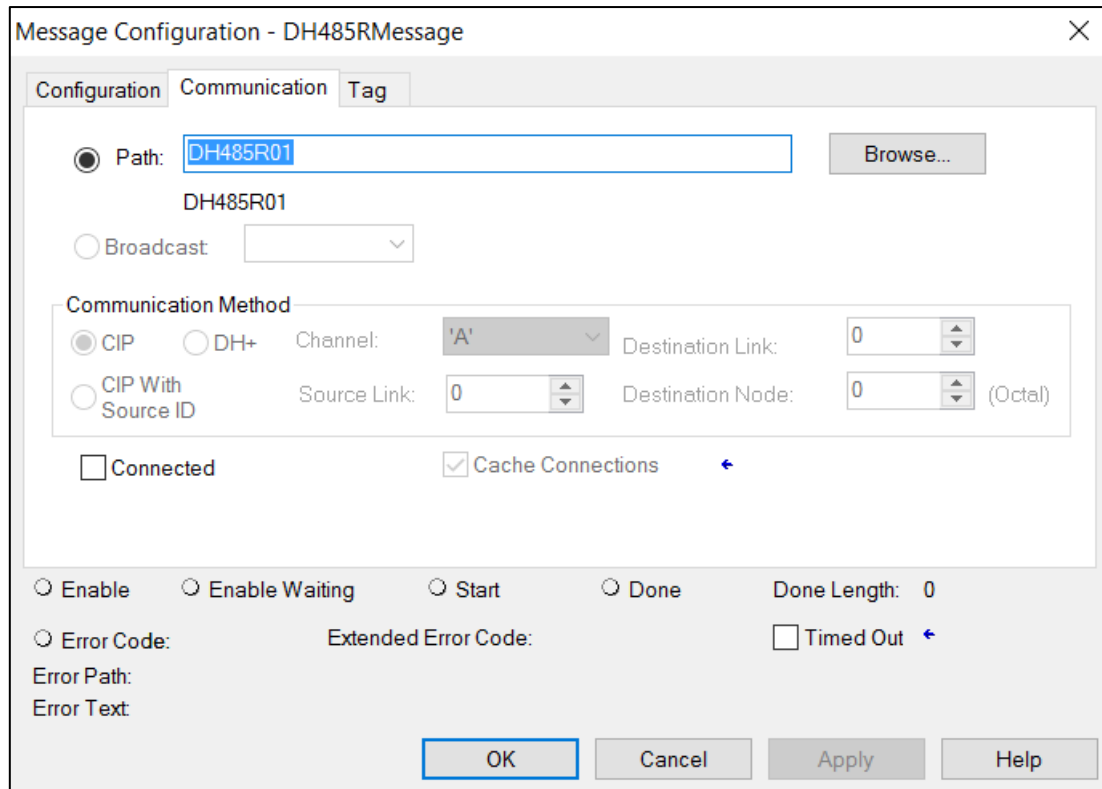

Figure 4.4. - Message Configuration - Communication

The Path must be configured to that of the DH485 Router/B. If the DH485 Router/B has been added in the I/O tree, then the Browse option can be used to select the path.

Alternatively, enter the CIP path in the format :

**1,X,2,IP** , where

1 represents the backplane port,

X represents the slot of the Ethernet bridge module,

2 represents the Ethernet port of the Ethernet bridge module and

IP represents the IP address of the DH485 Router/B.

e.g. **1,1,2,192.168.1.41**

The request tag (e.g. DH485RMsgrequest) should be configured as follows :

- DH485RMsgRequest	{...}	{..}		AparianDH485RMsgRequest
+ DH485RMsgRequest.DestinationNode	5		Decimal	SINT
+ DH485RMsgRequest.DF1DataFileAddress	'N10:0'	{..}		STRING
- DH485RMsgRequest.Function	{...}	{..}		AparianDH485RMsgFunctionType
- DH485RMsgRequest.Function.PLC5TypedRead	1		Decimal	BOOL
- DH485RMsgRequest.Function.PLC5TypedWrite	0		Decimal	BOOL
- DH485RMsgRequest.Function.SLCTypedRead	0		Decimal	BOOL
- DH485RMsgRequest.Function.SLCTypedWrite	0		Decimal	BOOL
- DH485RMsgRequest.DataType	{...}	{..}		AparianDH485RMsgDataType
- DH485RMsgRequest.DataType.BOOLEAN	0		Decimal	BOOL
- DH485RMsgRequest.DataType.INT	1		Decimal	BOOL
- DH485RMsgRequest.DataType.REAL	0		Decimal	BOOL
+ DH485RMsgRequest.ElementCount	16		Decimal	INT
+ DH485RMsgRequest.RequestData	{...}	{..}	Decimal	INT[128]
DH485RMsgTrigger	0		Decimal	BOOL

Figure 4.5. - Unscheduled Message Request Tag

Parameter	Description
Destination Node	The DH485 node address of the destination device.
Data File Address	A string representing the Data File Address of the destination DH485 device. E.g. N10:0
Function	Set the bit of the function required : PLC5 Typed Read PLC5 Typed Write SLC Typed Read SLC Typed Write Only one function can be set.
Data Type	Set the bit of the destination Data Type : Boolean Int (integer) Real (float) Only one function can be set.
Element Count	The number of destination elements defined in the Data Type field.
Request Data	The Data array (expressed as an IINT array) to be written to the destination node. This field is ignored for Reade functions.

Table 4.4. - Unscheduled Message Request Parameters

[-] DH485RMsgeResponse	{ ... }	{ .. }		AparianDH485RMsgResponse
+ DH485RMsgeResponse.Status	0		Decimal	INT
+ DH485RMsgeResponse.ResponseLength	0		Decimal	INT
+ DH485RMsgeResponse.ResponseData	{ ... }	{ .. }	Decimal	INT[128]

Figure 4.6. - Unscheduled Message Response Tag

Parameter	Description
Status	The status returned by the destination DH485 device. A value of zero indicates success.
Response Length	The number of bytes returned by the destination DH485 device.
Response Data	The data response from the destination DH485 device expressed as an INT array.

Table 4.5. - Unscheduled Message Response Parameters

After the message has been executed successfully (Msg.DN) the Response Data should be copied (using a COP instruction) to the required Data Tag of an appropriate data type.

## 4.4. TRANSPARENT MESSAGING

When the module is in transparent mode the user can message a DH485 node using the Logix SLC Message instruction as shown below. When doing an SLC Read the source element will be the file address of the destination node and the destination element will be the Logix tag to where the response data will be copied. When doing an SLC Write the source element will be the Logix tag where the data is that must be written, and the destination element is the file address of the destination node.

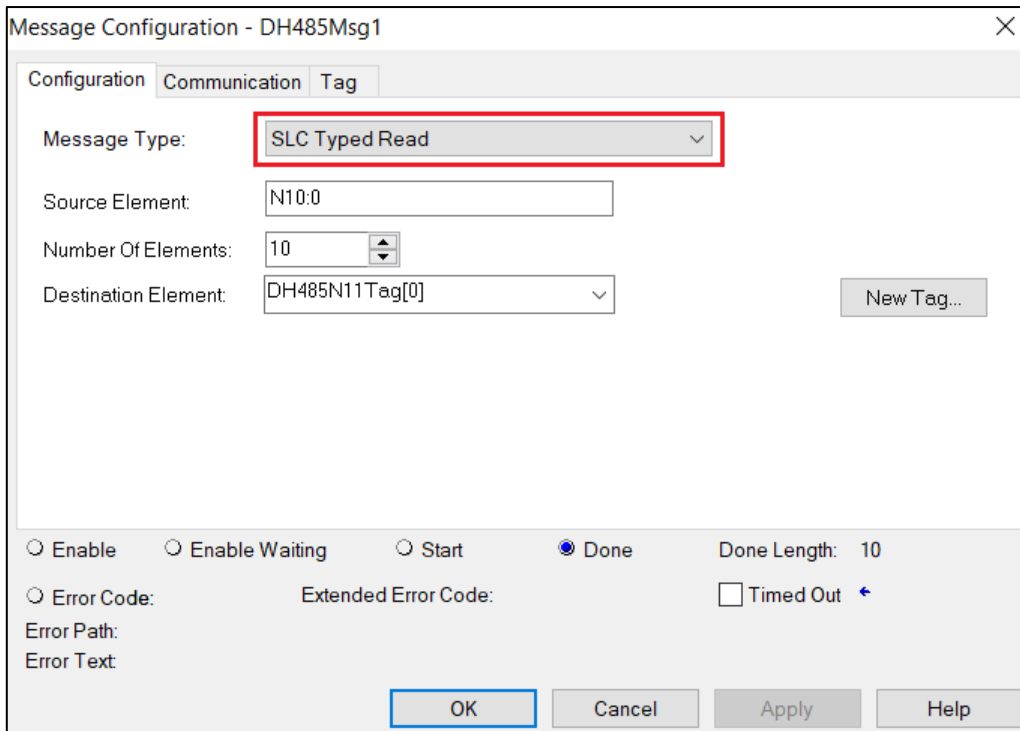

Figure 4.7. – Logix SLC Read/Write Message Type

The user will also need to enter the communication path of the destination DH485 node. The path will be to the DH485 Router/B followed by **Port 3** (which is the DH485 port) and then followed by the destination DH485 node address (which in the example below is 5).

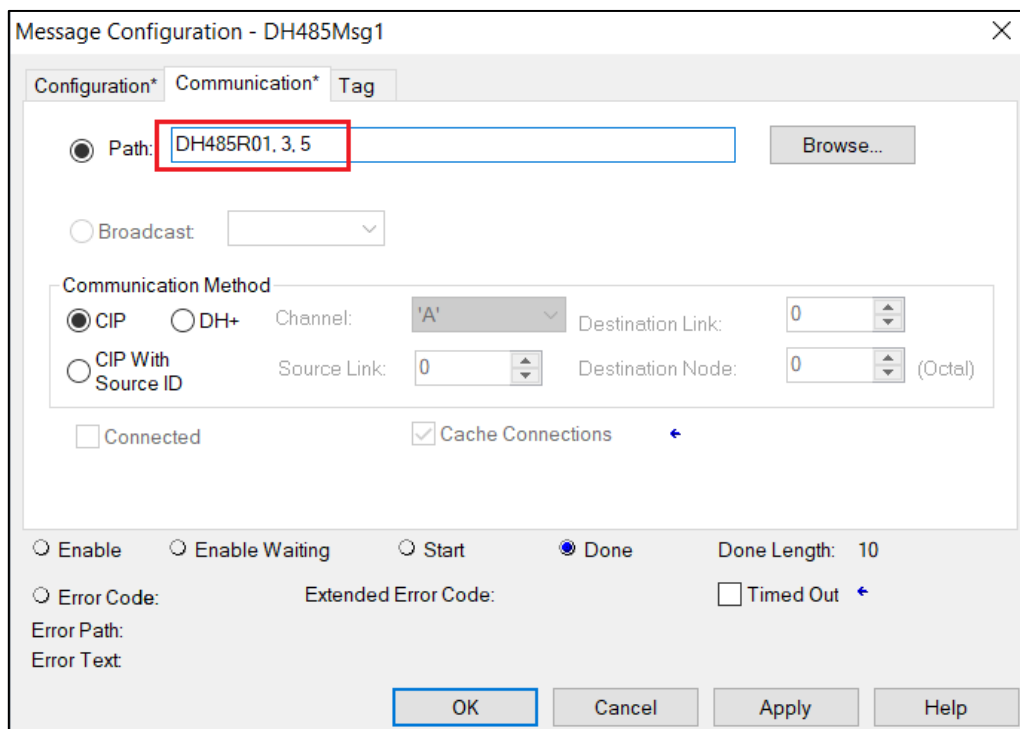

Figure 4.8. – Logix SLC Read/Write Communication Path

## 5. DIAGNOSTICS

### 5.1. LEDS

The module provides six LEDs for diagnostics purposes as shown in the front view figure below. A description of each LED is given in the table below.



Figure 5.1 - DH485 Router front view

LED	Description
Ok	<p>The module LED will provide information regarding the system-level operation of the module.</p> <p>If the LED is <b>red</b>, then the module is not operating correctly. For example, if the module application firmware has been corrupted or there is a hardware fault the module will have a red Module LED.</p> <p>If the LED is <b>green (flashing)</b>, then the module has booted and is running correctly <b>without</b> any application configuration loaded.</p> <p>If the LED is <b>green (solid)</b>, then the module has booted and is running correctly <b>with</b> application configuration loaded.</p>



A / B	The Ethernet LED will light up when an Ethernet link has been detected (by plugging in a connected Ethernet cable). The LED will flash every time traffic is detected. This module has two Ethernet ports A and B. Each LEDs represents each specific port.
Act	The activity LED is used for the DH485 Routing. Every time there is a successful DH485 routing transaction the LED will flash green. The LED will flash red if the routing was unsuccessful (e.g. Logix Tag does not exist).
232	The 232 LED is used for the RS232 port. Every time there is a successful DH485 packet on RS232 the LED will flash green. The LED will flash red if the DH485 packet failed (e.g. checksum failure).
485	The 485 LED is used for the DH485 port. Every time there is a successful DH485 packet on DH485 the LED will flash green. The LED will flash red if the DH485 packet failed (e.g. checksum failure).

Table 5.1 - Module LED operation

## 5.2. MODULE STATUS MONITORING IN SLATE

The DH485 Router/B can provide a range of statistics which can assist with module operation, maintenance, and fault finding. The statistics can be accessed in full by Slate or using the web server in the module.

To view the module's status in the Aparian-Slate environment, the module must be online. If the module is not already Online (following a recent configuration download), then right-click on the module and select the *Go Online* option.

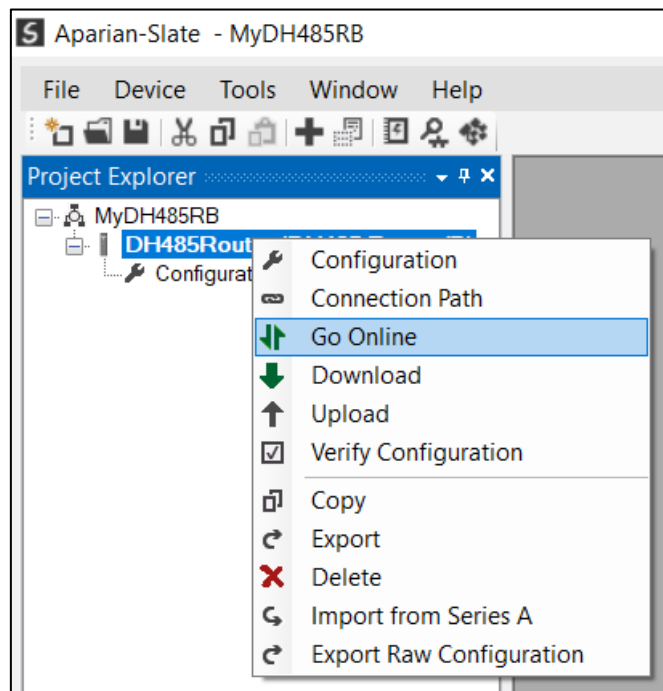

Figure 5.2. - Selecting to Go Online

The Online mode is indicated by the green circle behind the module in the Project Explorer tree.

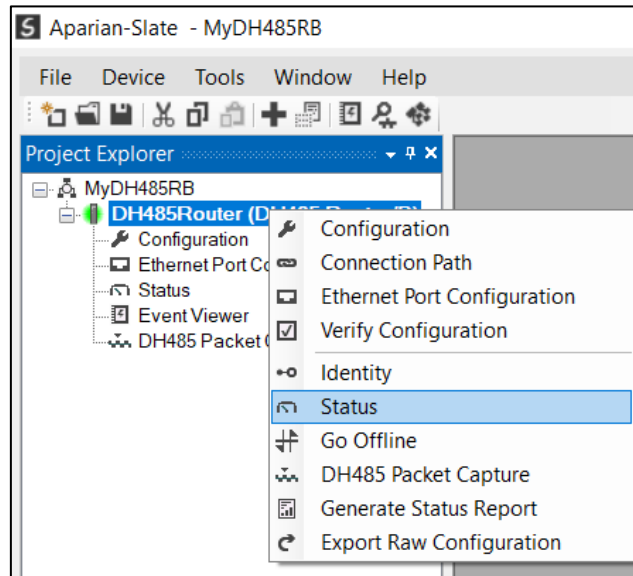

Figure 5.3. - Selecting online Status

The Status monitoring window can be opened by either double-clicking on the **Status** item in the Project Explorer tree, or by right-clicking on the module and selecting **Status**.

The status window contains multiple tabs to display the current status of the module.

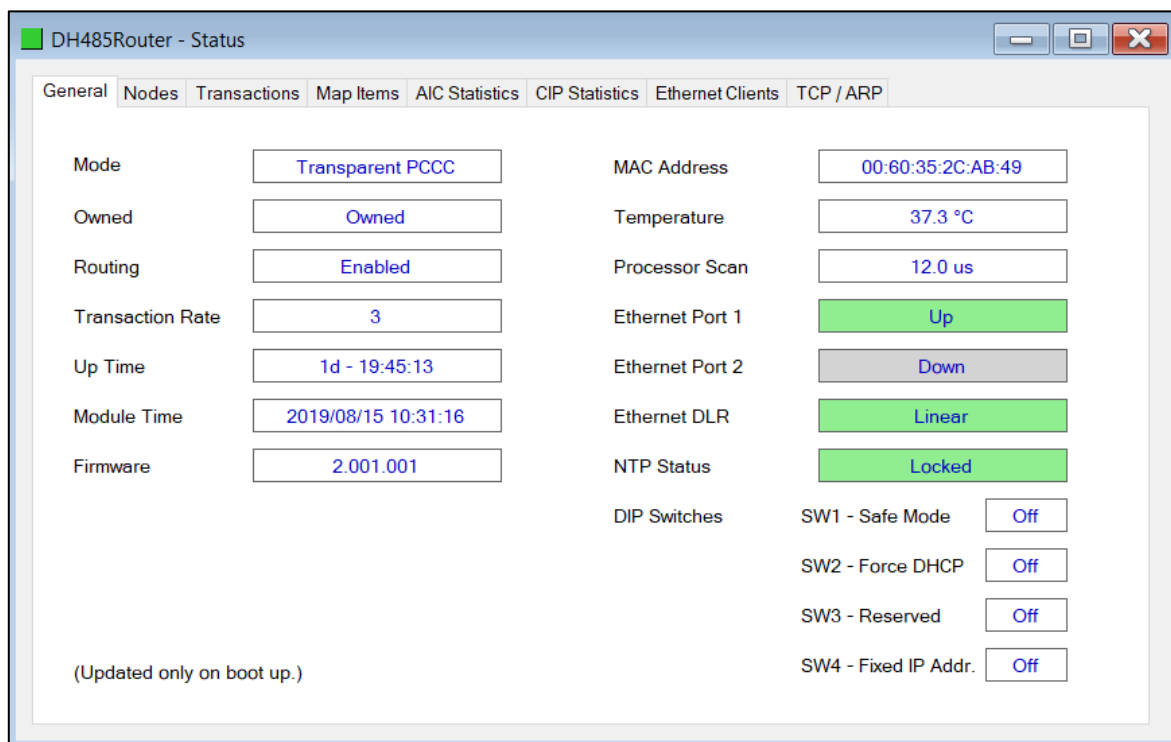

Figure 5.4. - Status monitoring - General

The General tab displays the following general parameters and can also be used to set the module time to the PC time:

Parameter	Description
Mode	Indicates the current operating mode:  Transparent, Reactive Tag, Scheduled Tag, Unscheduled, or AIC.
Owned	Indicates whether or not the module is currently owned (Class 1) by a Logix controller.
Routing	Indicates whether the routing of module is enabled or inhibited. The routing operation can be inhibited in the output assembly of the module.
Transaction Rate	The transaction rate is the number of DH485 messages per second that the module is currently routing.
Up Time	Indicates the elapsed time since the module was powered-up.
Module Time	Indicates the module's internal time. The module time is stored in UTC (Universal Coordinate Time) but displayed on this page according to the local PC Time Zone settings.
Firmware	The firmware revision of the module.
MAC Address	Displays the module's unique Ethernet MAC address.
Temperature	The internal temperature of the module.
Processor Scan	The amount of time (microseconds) taken by the module's processor in the last scan.
Ethernet Port 1 / 2	This is the status of each Ethernet port.  <b>Down</b> The Ethernet connector has <b>not been</b> successfully connected to an Ethernet network.  <b>Up</b> The Ethernet connector has successfully connected to an Ethernet network.  <b>Mirror Enabled</b> The Ethernet port is mirroring the traffic on the other Ethernet port.
Ethernet DLR	The status of the Ethernet DLR.  <b>Disabled</b> Device Level Ring functionality has been disabled.

	<p><b>Linear</b> The DLR functionality has been enabled and the Ethernet network architecture is linear.</p> <p><b>Ring – Fault</b> The DLR functionality has been enabled and the Ethernet network architecture is ring, but there is a fault with the network.</p> <p><b>Ring – Ok</b> The DLR functionality has been enabled and the Ethernet network architecture is ring and is operating as expected.</p>
NTP Status	<p>The status of the local NTP Client.</p> <p><b>Disabled</b> The NTP time synchronization has been disabled.</p> <p><b>Locked</b> NTP time synchronization has been enabled and the DH485 Router has locked onto the target time server.</p> <p><b>Not Locked</b> NTP time synchronization has been enabled and the DH485 Router has not locked onto the target time server.</p>
DIP Switch Position	<p>The status of the DIP switches when the module booted.</p> <p>Note that this status will not change if the DIP switches are altered when the module is running.</p>

Table 5.2 - Parameters displayed in the Status Monitoring – General Tab

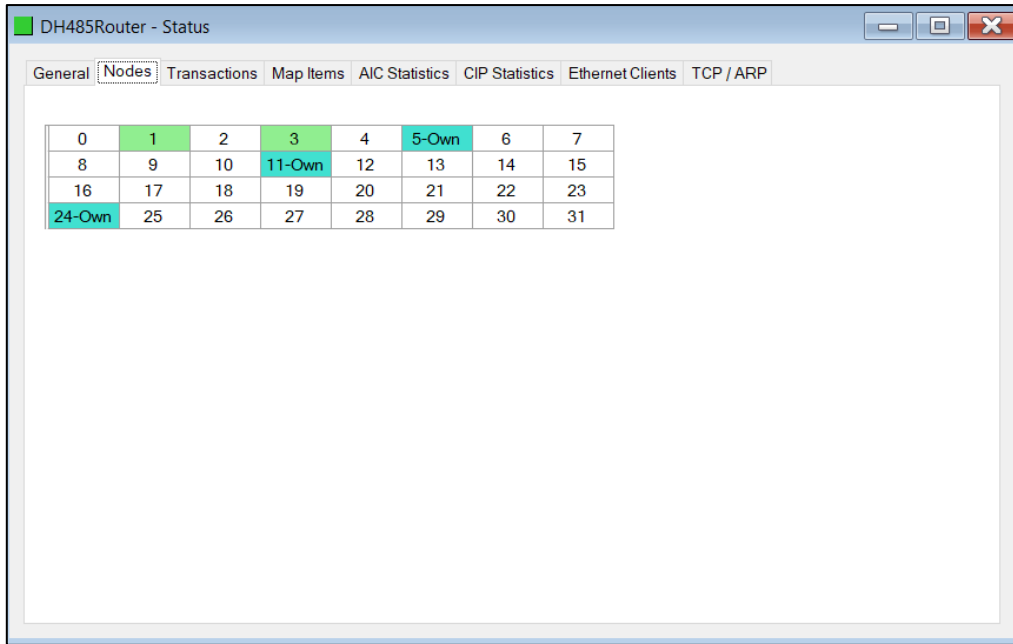

Figure 5.5. - Status monitoring - Nodes

This tab will display all the active nodes on the DH485 network. When the node address is followed by *Own* it indicates that the active node on the network is the node configured on the local DH485 Router/B. When using Reactive or Transparent PCCC modes more than one node on the network can belong to the local DH485 Router/B.

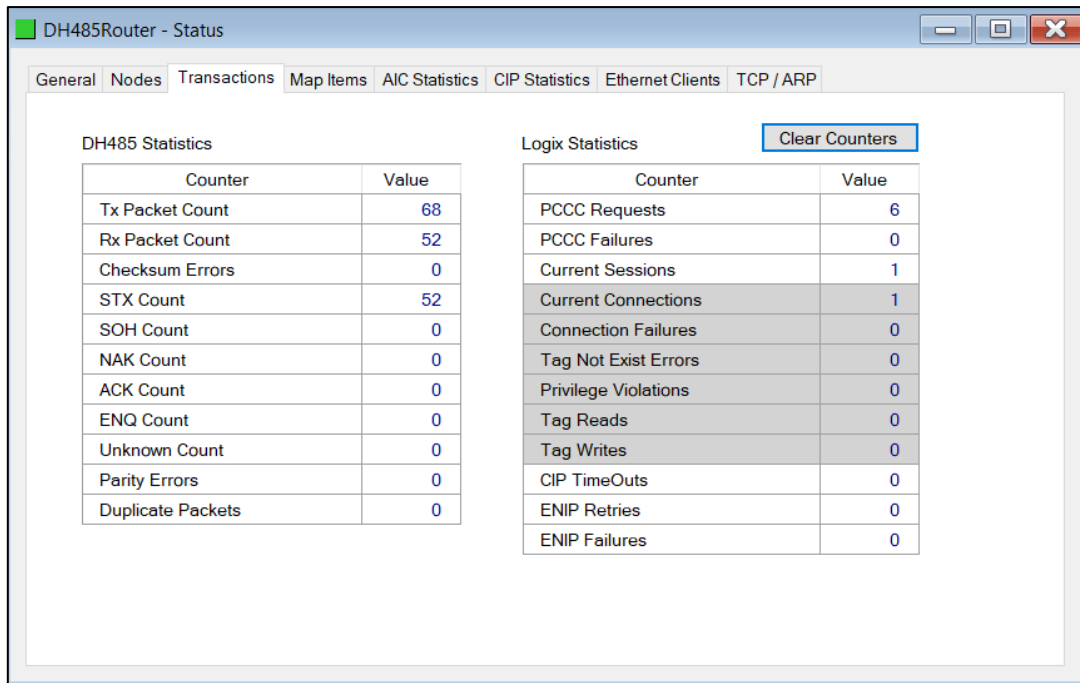

Figure 5.6. - Status monitoring - Transactions

The Transactions tab displays the statistics associated with the following:

- DH485 messages
- PCCC messages (Transparent and Scheduled Tag Mode)
- Logix Tag Mapping (Reactive Tag and Scheduled Tag Mode)

Statistic	Description
Tx Packet Count	The number of DH485 packets sent by the module.
Rx Packet Count	The number of DH485 packets received by the module.
Checksum errors	The number of corrupted DH485 packets received by the module.
STX count	The number of DH485 STX (Start of Text) delimiters received by the module.
SOH count	The number of DH485 SOH (Start of Header) delimiters received by the module.
NAK count	The number of NAK (Negative Acknowledge) DH485 packets received by the module.
ACK count	The number of ACK (Acknowledge) DH485 packets received by the module.
ENQ count	The number of ENQ (Enquiry) DH485 packets received by the module.
Unknown count	The number of unknown packets received by the module.
Parity errors	The number of bytes with parity errors received by the module.
Duplicate packet count	The number of duplicate packets received by the module.

Table 5.3 – DH485 statistics

The following PCCC statistics are only relevant when the module is running in either Transparent PCCC or Unscheduled mode.

Statistic	Description
PCCC Requests	The number of EtherNet/IP PCCC requests that have been sent to a Logix controller.
PCCC Failures	The number of failed EtherNet/IP PCCC responses that have been received by the DH485 Router/B from a Logix controller.
Current Sessions	The current number of open EtherNet/IP PCCC sessions.

Table 5.4 - PCCC statistics

The following Tag Mapping statistics are only relevant when the module is running in either Reactive Tag or Scheduled Tag mode.

Statistic	Description
Current Connections	The number of current open class 3 connections.
Connection Failures	The number of failed attempts at establishing a class 3 connection with a Logix controller.
Tag Not Exist Errors	The number of tag read and tag write transactions that failed due to the destination tag not existing.
Privilege Violation Errors	The number of tag read and tag write transactions that failed due to a privilege violation error. This may be caused by the External Access property of the Logix tag being set to either None or Read Only.
Tag Reads	The number of tag read transactions executed by the DH485 Router/B module.
Tag Writes	The number of tag write transactions executed by the DH485 Router/B module.
CIP Timeout	This count increases when no response was received for the Tag Read/Write.
ENIP Retries	This count increases when no response was received from the Logix Controller by the time the ENIP timeout is reached.
ENIP Failures	This count increases when the ENIP Retry Limit is reached and no response has been received from the Logix Controller.

Table 5.5 - Tag Mapping statistics

The Map Items tab will display the successful packet counts processed by each mapping item. If an item count changes, then the success count field will be displayed with a green background for approximately 3 seconds. This provides quick visual feedback as to which items are currently active.

The fields in the map items will adjust to suite the appropriate mode. No items are displayed in Unscheduled mode.

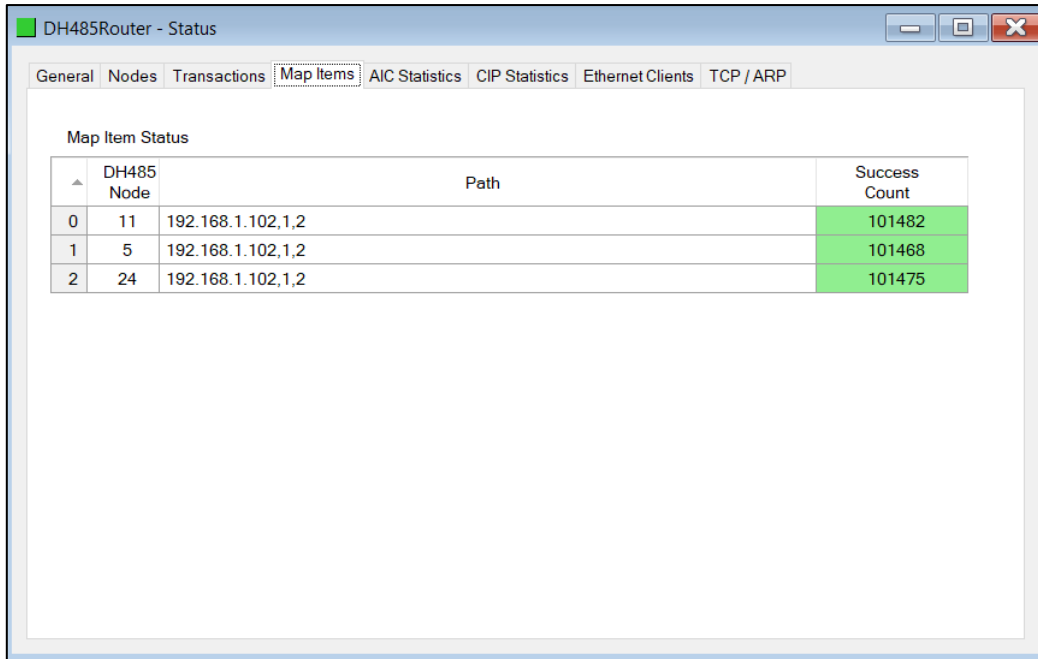

	DH485 Node	Path	Success Count
0	11	192.168.1.102,1,2	101482
1	5	192.168.1.102,1,2	101468
2	24	192.168.1.102,1,2	101475

Figure 5.7. - Map Item status

The AIC Statistics tab is shown below.

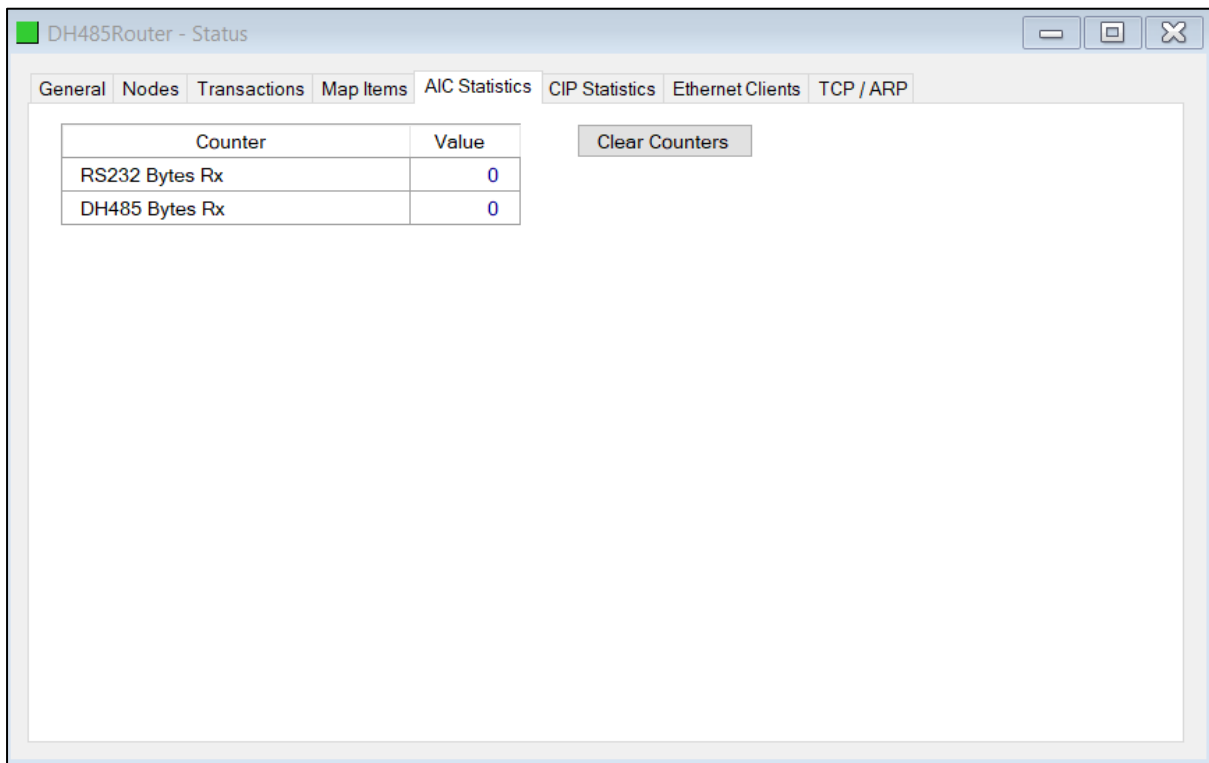

Counter	Value
RS232 Bytes Rx	0
DH485 Bytes Rx	0

Clear Counters

Figure 5.8. - Status monitoring – AIC Statistics



The AIC Statistics tab displays the statistics associated with the following:

Statistic	Description
RS232 Bytes Rx	The number of packets received on the RS232 port and forwarded to the DH485 port.
DH485 Bytes Rx	The number of packets received on the DH485 port and forwarded to the RS232 port.

Table 5.6 – AIC Statistics

The Common Industrial Protocol (CIP) Statistics tab is shown below.

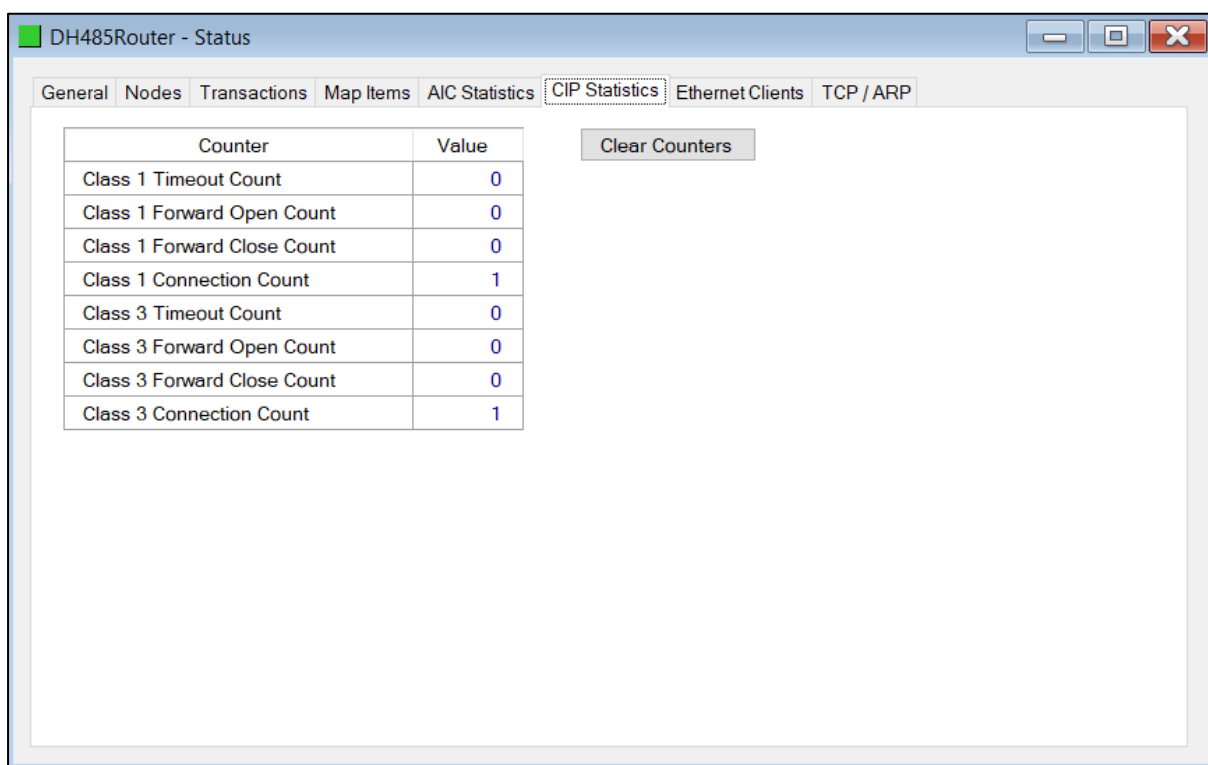

Figure 5.9. - Status monitoring – CIP Statistics

The CIP Statistics tab displays the statistics associated with the following:

Statistic	Description
Class 1 Timeout Count	Number of times a Class 1 connection has timed out
Class 1 Forward Open Count	Number of Class 1 Connection establish attempts
Class 1 Forward Close Count	Number of Class 1 Connection close attempts
Class 1 Connection Count	Number of Class 1 Connections currently active
Class 3 Timeout Count	Number of times a Class 3 connection has timed out

Class 3 Forward Open Count	Number of Class 3 Connection establish attempts
Class 3 Forward Close Count	Number of Class 3 Connection close attempts
Class 3 Connection Count	Number of Class 3 Connections currently active

Table 5.7 – CIP Statistics

### 5.3. DH485 PACKET CAPTURE

The module provides the capability to capture the DH485 traffic for analysis. This will allow the user and the support team to resolve any possible issue on site.

To invoke the capture of the module, double-click on the DH485 Packet Capture item in the Project Explorer tree.

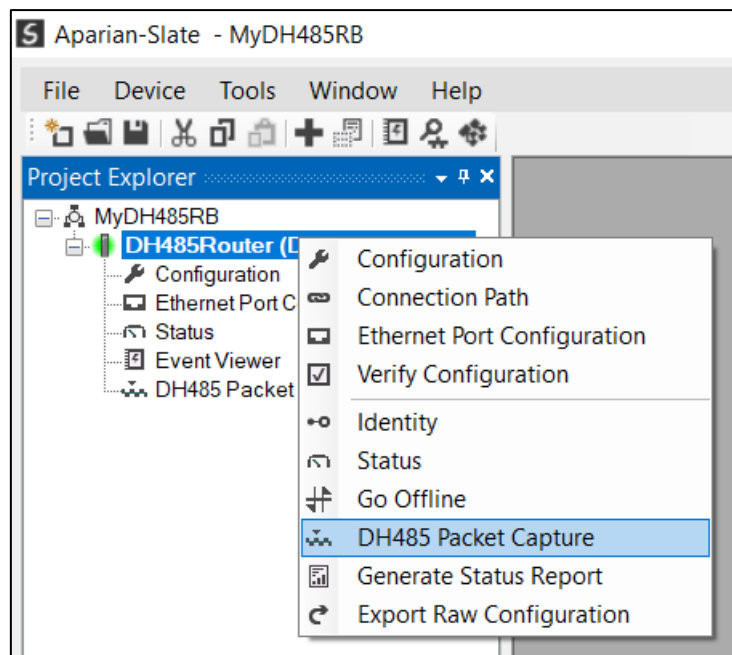

Figure 5.10. - Selecting DH485 Packet Capture

The DH485 Packet Capture window will open and automatically start capturing all DH485 packets.



**NOTE:** The module keeps a circular buffer of the last 20 DH485 packets, and thus there may be up to 20 packets in the capture that were received / sent before the capture was initiated.



**NOTE:** The DH485 packet capture is not available in AIC mode.

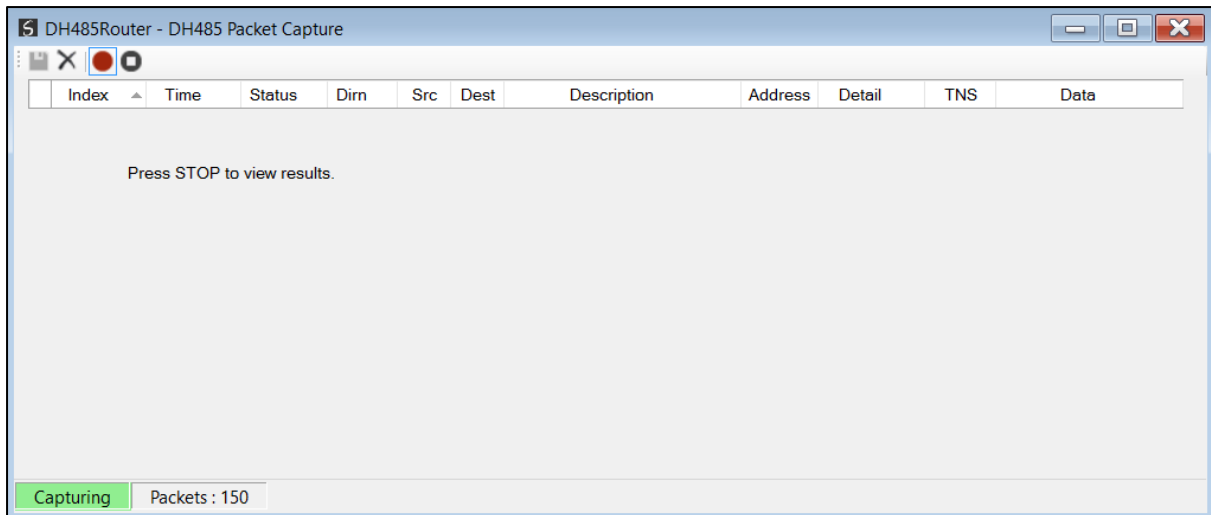

Figure 5.11 - DH485 packet capture

To display the captured DH485 packets, the capture process must first be stopped, by pressing the Stop button.

Index	Time	Status	Dirn	Src	Dest	Description	Address	Detail	TNS	Data
515166	0d - 02:35:32.810	Ok	Rx	10	24	Poll Node		Polling 24		10 02 98 01 8A 80 10 03 20 0B
515167	0d - 02:35:32.870	Ok	Rx	0	0	ProtectedTypedLogicalRead	N11:0	Size=40	1D6	10 02 81 08 8A 01 01 0A 0F 00 D6 01 A2 28 0B 8...
515168	0d - 02:35:32.880	Ok	Rx	1	10	Ack Response				10 02 8A 18 81 10 03 8A 4E
515169	0d - 02:35:32.890	Ok	Rx	10	0	Token Pass		10 to 0		10 02 80 00 8A 10 03 0E A1
515170	0d - 02:35:32.890	Ok	Tx	0	0	Reply		Success	1F0A	10 02 82 08 80 01 01 D2 4F 00 0A 1F 00 00 37 0...
515171	0d - 02:35:33.030	Ok	Rx	2	0	Ack Response				10 02 80 18 82 10 03 89 66
515172	0d - 02:35:33.030	Ok	Tx	0	1	Token Pass		0 to 1		10 02 81 00 80 10 03 09 FD
515173	0d - 02:35:33.070	Ok	Rx	0	0	Reply		Success	1D6	10 02 8A 88 81 01 01 2C 4F 00 D6 01 00 00 37 0...
515174	0d - 02:35:33.080	Ok	Rx	10	1	Ack Response				10 02 81 18 8A 10 03 8F 5A
515175	0d - 02:35:33.090	Ok	Rx	1	2	Token Pass		1 to 2		10 02 82 00 81 10 03 08 29
515176	0d - 02:35:33.100	Ok	Rx	0	0	ProtectedTypedLogicalRead	N13:0	Size=10	9F0C	10 02 85 08 82 01 01 0A 0F 00 0C 9F A2 0A 0D 8...
515177	0d - 02:35:33.100	Ok	Tx	5	2	Ack Response				10 02 82 18 85 10 03 8A EE
515178	0d - 02:35:33.120	Ok	Rx	2	3	Token Pass		2 to 3		10 02 83 00 82 10 03 09 25

Figure 5.12. - DH485 Packet Capture complete

The captured DH485 packets are tabulated as follows:

Statistic	Description
Index	The packet index, incremented for each packet sent or received.
Time	The elapsed time since the module powered up.
Status	The status of the packet. Received packets are checked for valid DH485 constructs and valid checksums.
Dirn	The direction of the packet, either transmitted (Tx) or received (Rx).
Src	DH485 node address of the message source.
Dest	DH485 node address of the message destination.

Description	Brief description of the packet, usually the command.
Address	The string representing a PLC data address, where applicable.
Detail	Additional details associated with command.
TNS	Transaction number. Used to match request and reply messages.
Data	The packet's raw data displayed in space delimited hex.

Table 5.8. - DH485 Packet Capture fields

The packet capture can be saved to a file for further analysis, by selecting the Save button on the toolbar. Previously saved DH485 Packet Capture files can be viewed by selecting the DH485 Packet Capture Viewer option in the tool's menu.

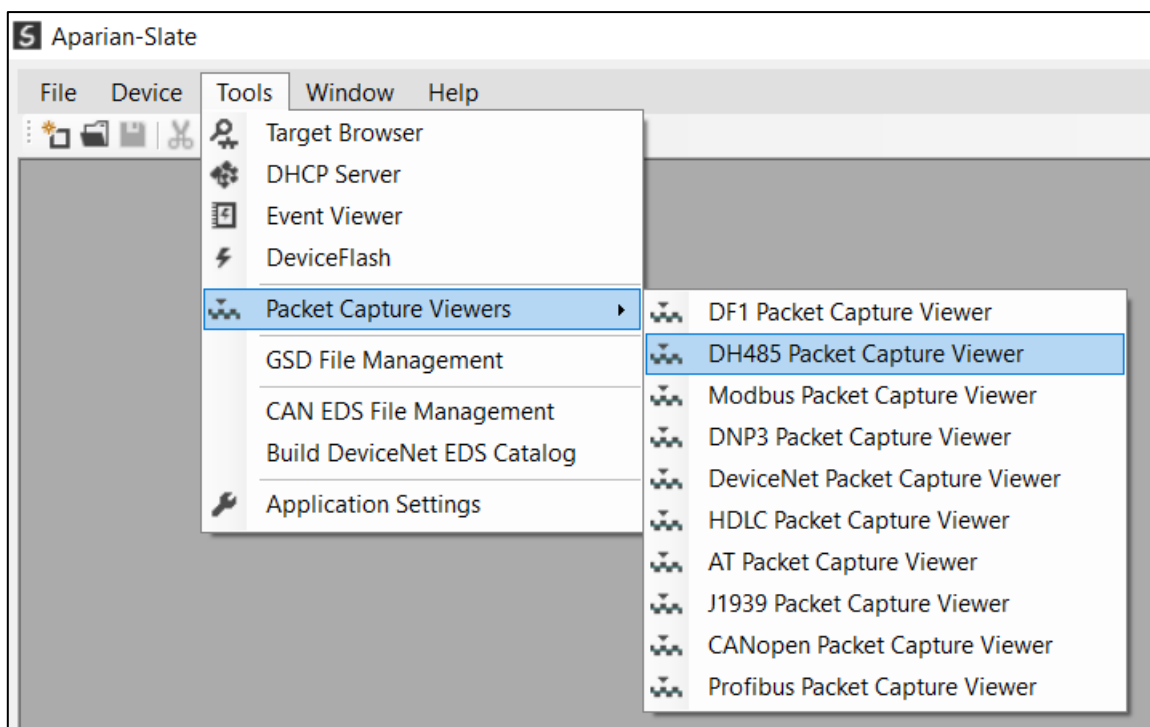

Figure 5.13. - Selecting the DH485 Packet Capture Viewer

## 5.4. MODULE EVENT LOG

The DH485 Router/B module logs various diagnostic records to an internal event log. These logs are stored in non-volatile memory and can be displayed using Slate or via the web interface.

To view them in Slate, select the **Event Viewer** option in the Project Explorer tree.

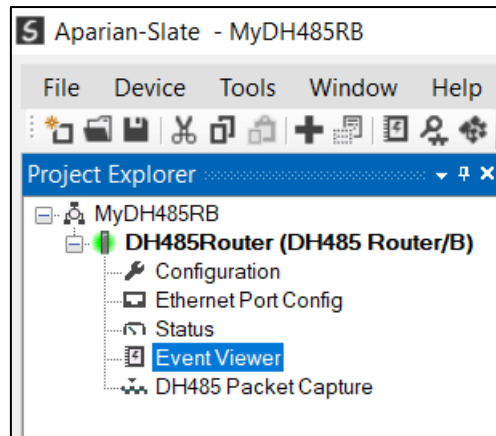

Figure 5.14. - Selecting the module Event Log

The Event Log window will open and automatically read all the events from the module.

The log entries are sorted so as to have the latest record at the top. Custom sorting is achieved by double-clicking on the column headings.

Index	Time	Up Time	Event
39	2017/05/02 08:33:04	0d - 00:00:46	DH485 Router config valid
38	2017/05/02 08:32:20	0d - 00:00:02	Ethernet link up
37	2017/05/02 08:32:20	0d - 00:00:02	Application code running
36	2017/05/02 08:32:18	0d - 00:00:00	Config CRC fail
35	2017/05/02 08:32:15	0d - 00:29:34	Module reset
34	2017/05/02 08:32:11	0d - 00:29:34	Firmware update started
33	2017/05/02 08:02:41	0d - 00:00:03	DH485 Router config valid
32	2017/05/02 08:02:38	0d - 00:00:01	Ethernet link up
31	2017/05/02 08:02:38	0d - 00:00:01	Application code running
30	2017/05/02 08:02:37	0d - 00:00:00	Config CRC fail
29	2017/05/02 08:02:34	0d - 00:24:43	Module reset
28	2017/05/02 08:02:30	0d - 00:24:43	Firmware update started
27	2017/05/02 07:40:35	0d - 00:02:48	DH485 Router config valid
26	2017/05/02 07:37:48	0d - 00:00:01	Ethernet link up
25	2017/05/02 07:37:48	0d - 00:00:01	Application code running
24	2017/05/02 07:37:47	0d - 00:00:00	Config CRC fail
23	2017/05/02 07:37:44	0d - 00:06:54	Module reset
22	2017/05/02 07:37:40	0d - 00:06:54	Firmware update started

Figure 5.15. – Module Event Log

The log can also be stored to a file for future analysis, by selecting the **Save** button in the tool menu.

To view previously saved files, use the Event Log Viewer option under the tools menu.

## 5.5. WEB SERVER

The DH485 Router/B provides a web server allowing a user without Slate or RSLogix 5000 to view various diagnostics of the module. This includes Ethernet parameters, system event log, advanced diagnostics, and application diagnostics (DH485 diagnostics).



**NOTE:** The web server is view **only** and thus no parameters or configuration can be altered from the web interface.

The screenshot shows a web browser window with the URL 192.168.1.186. The page header displays 'Module: DH485 Router/B Serial: 352CAB49 Firmware Rev: 2.001.001' and the Aparian logo. A left sidebar contains navigation buttons for Overview, Ethernet, Event Logs, Diagnostics, and Application, along with the website URL www.aparian.com. The main content area is a table of device information:

Device Name	DH485 Router/B
Serial number	352CAB49
Firmware Revision	2.001.001
Vendor Id	1370
Product Type	12
Product Code	115
Uptime	1d 20h 4m 16s
Date	2019/08/15
Time	08:50:19
Temperature	37.7296°C
Hardware MAC	00:60:35:2C:AB:49
System MAC	00:60:35:2C:AB:49
Switches at Startup	0:0:0:0
Switches Now	0:0:0:0
Ethernet Port 1	Link Up Port Mirror Disabled
Ethernet Port 2	Link down Port Mirror Disabled
SD Card Status	No SD Card

Copyright 2018 Aparian Inc. All rights reserved

Figure 5.16. - Web interface

# 6. TECHNICAL SPECIFICATIONS

## 6.1. DIMENSIONS

Below are the enclosure dimensions as well as the required DIN rail dimensions. All dimensions are in millimetres.

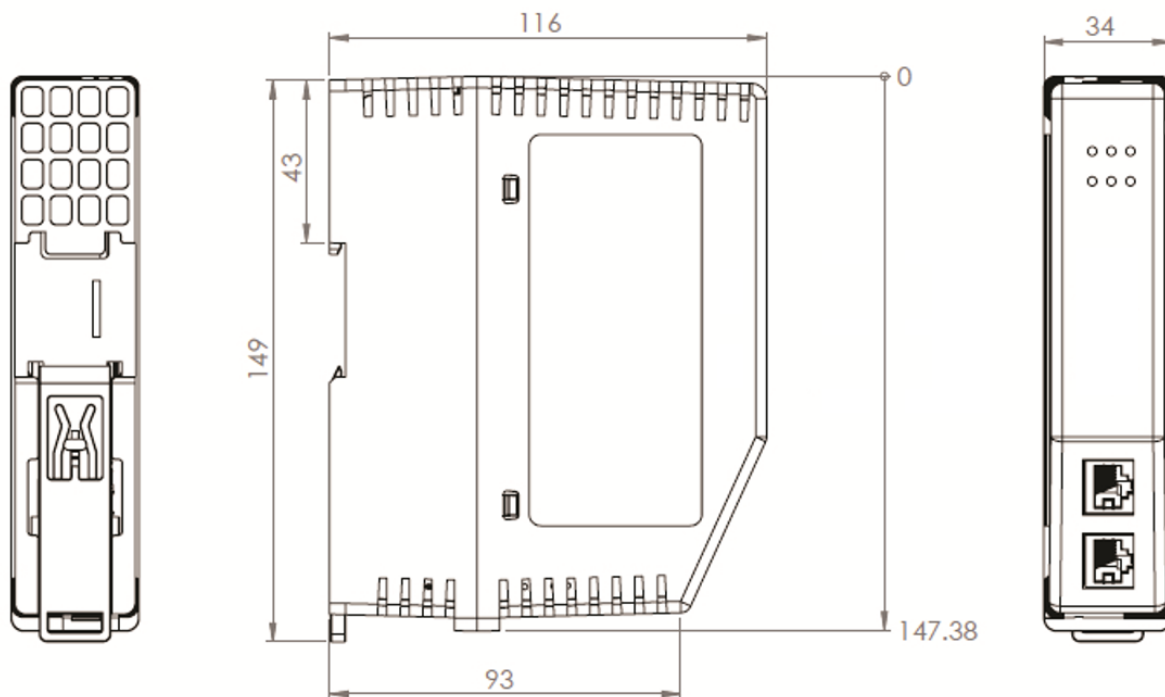

Figure 6.1 - DH485 Router/B enclosure dimensions

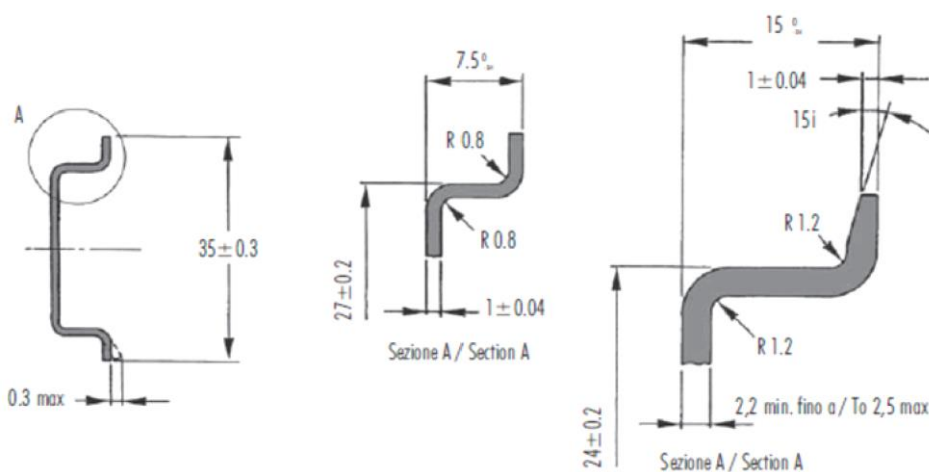

Figure 6.2 - Required DIN dimensions

## 6.2. ELECTRICAL

Specification	Rating
Power requirements	Input: 10 – 32V DC, (67 mA @ 24 VDC)
Voltage Fluctuations	Voltage fluctuations < ±10% Transient Over-voltages up to the levels of OVERVOLTAGE CATEGORY I
Power consumption	1.7 W 173 mA maximum
Connector	3-way terminal
Conductors	24 – 18 AWG
Earth connection	Yes, terminal based
Emissions	IEC61000-6-4
ESD Immunity	EN 61000-4-2
Radiated RF Immunity	IEC 61000-4-3
EFT/B Immunity	EFT: IEC 61000-4-4
Surge Immunity	Surge: IEC 61000-4-5
Conducted RF Immunity	IEC 61000-4-6

Table 6.1 - Electrical specification

## 6.3. ENVIRONMENTAL

Specification	Rating
Enclosure rating	IP20, NEMA/UL Open Type Indoor use only
Temperature	-20 – 70 °C
Relative Humidity	5% to 90% - No condensation
Pollution Degree	2
Altitude	< 2000 m

Table 6.2 - Environmental specification



## 6.4. ETHERNET

Specification	Rating
Connector	RJ45
Conductors	CAT5 STP/UTP
ARP connections	Max 40
TCP connections	Max 40
CIP connections	Max 10
Communication rate	10/100Mbps
Duplex mode	Full/Half
Auto-MDIX support	Yes
Controller Support	ControlLogix, CompactLogix, MicroLogix, SLC
Embedded switch	Yes, 2 x Ethernet ports

Table 6.3 - Ethernet specification

## 6.5. SERIAL PORT (RS232)

Specification	Rating
RS232 Connector	9-way terminal (shared with DH485)
RS232 Conductor	24 – 18 AWG
Electrical Isolation	1000 Vdc

Table 6.4 – RS232 Serial Port specification

## 6.6. SERIAL PORT (DH485)

Specification	Rating
DH485 Connector	9-way terminal (shared with DH485)
DH485 Conductor	24 – 18 AWG
Electrical Isolation	1500 Vrms for 1 minute.

Table 6.5 – DH485 Serial Port specification

## 6.7. DH485

Specification	Rating
Protocol	DH485
Physical Port	RS485 or RS232
BAUD	1200, 2400, 4800, 9600, 19200, 38400, 57600, 115200
Parity	Even
Data bits	8
Stop bits	1
Error detection	CRC
Transparent mode mapping	Max 20 routes
Logix Tag mode mapping	Max 20 routes
Reactive Tag Mode Message Support	PLC-5 Typed Read, PLC-5 Typed Write, SLC Typed Read, SLC Typed Write
Scheduled Tag Mode Message Support	PLC-5 Typed Read, PLC-5 Typed Write, SLC Typed Read, SLC Typed Write
Rockwell Automation Controller programming support	SLC5xx range

Table 6.6 - DH485 specification

## 6.8. CERTIFICATIONS





Certification	Mark
CE Mark	
RoHS2 Compliant	
UL Mark File: E494895	
ODVA Conformance	

Table 6.7 – Certifications

# 7. APPENDIX A – CONNECTION DIAGRAMS

## 7.1. DH485R/B – 1747-AIC

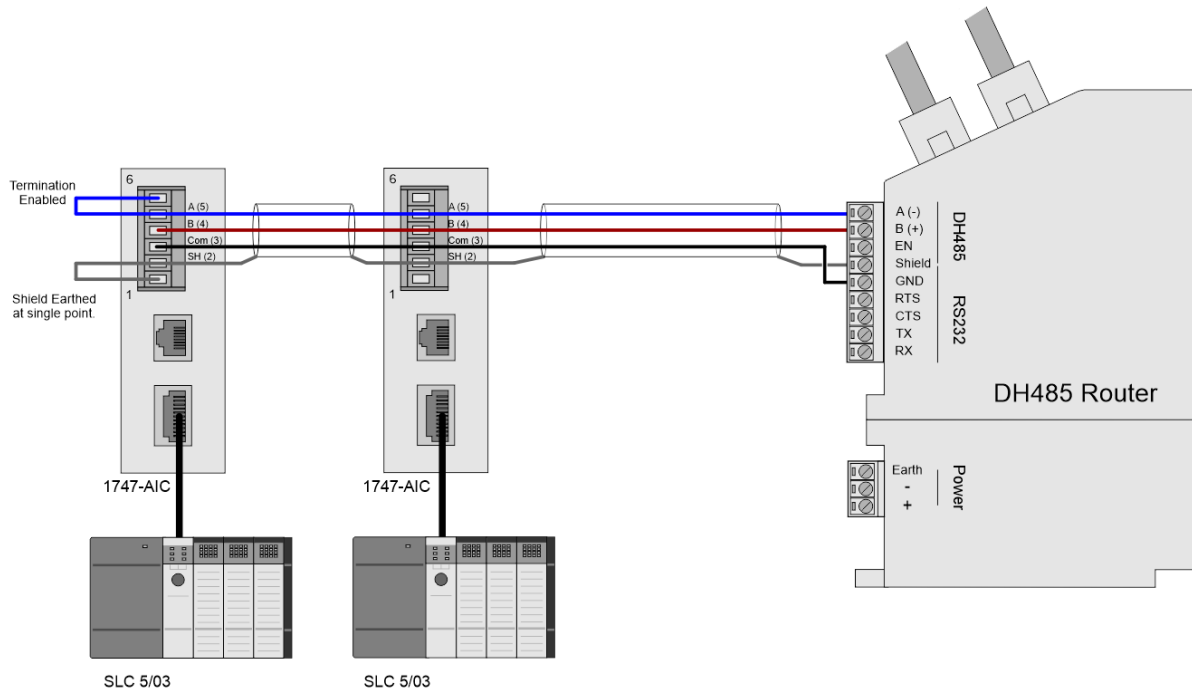

Figure 7.1 – DH485R/B – 1747-AIC

## 7.2. DH485R/B – SLC500, 5/01, 5/02, 5/03 (DIRECT)

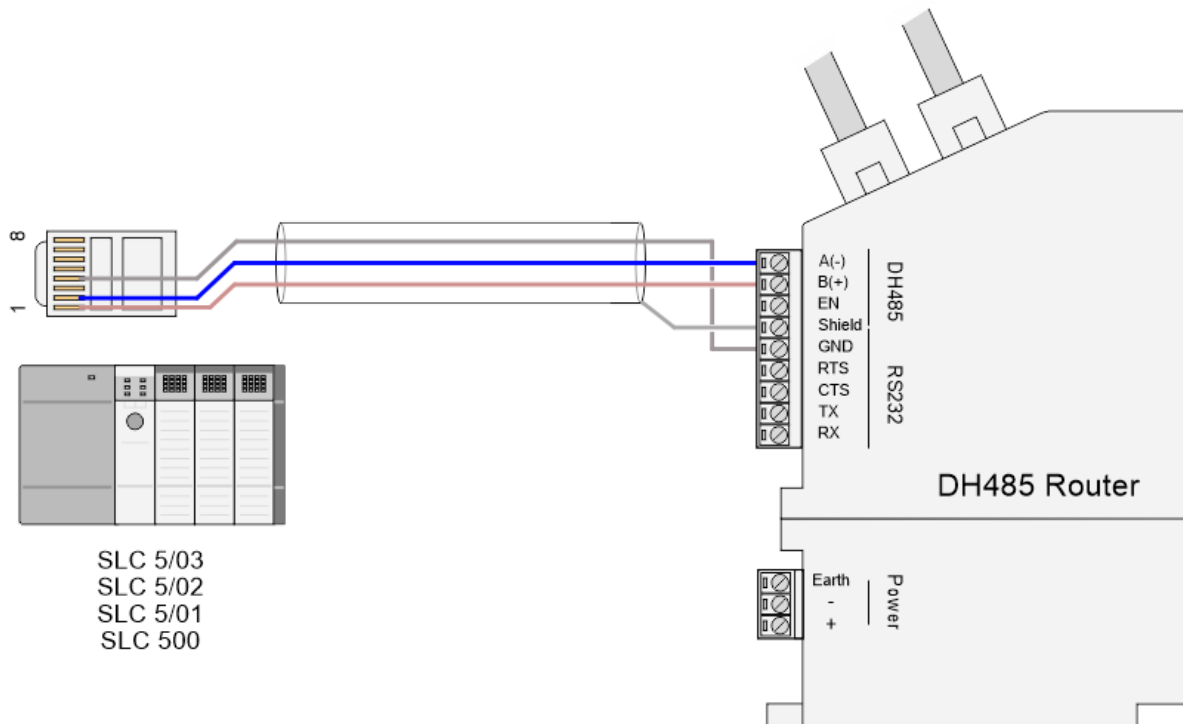

Figure 7.2 – DH485R/B – SLC500, 5/01, 5/02, 5/03 (Direct)

### 7.3. DH485R/B - MICROLOGIX 1100 / 1400

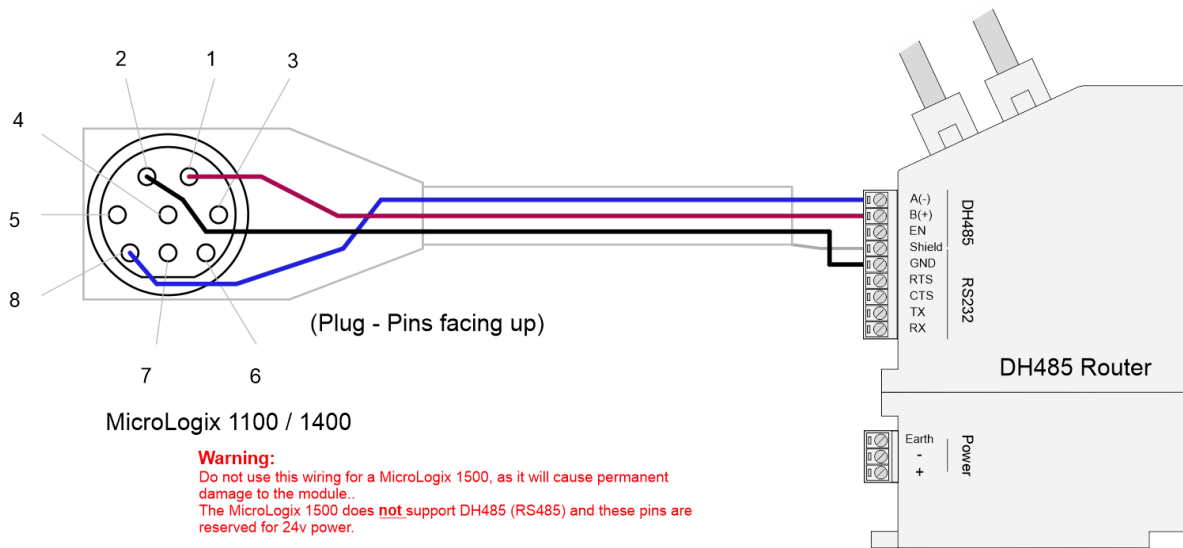

Figure 7.3 – DH485R/B – MicroLogix 1100 / 1400

## 7.4. DH485R/B - MICROLOGIX 1500 (RS232)

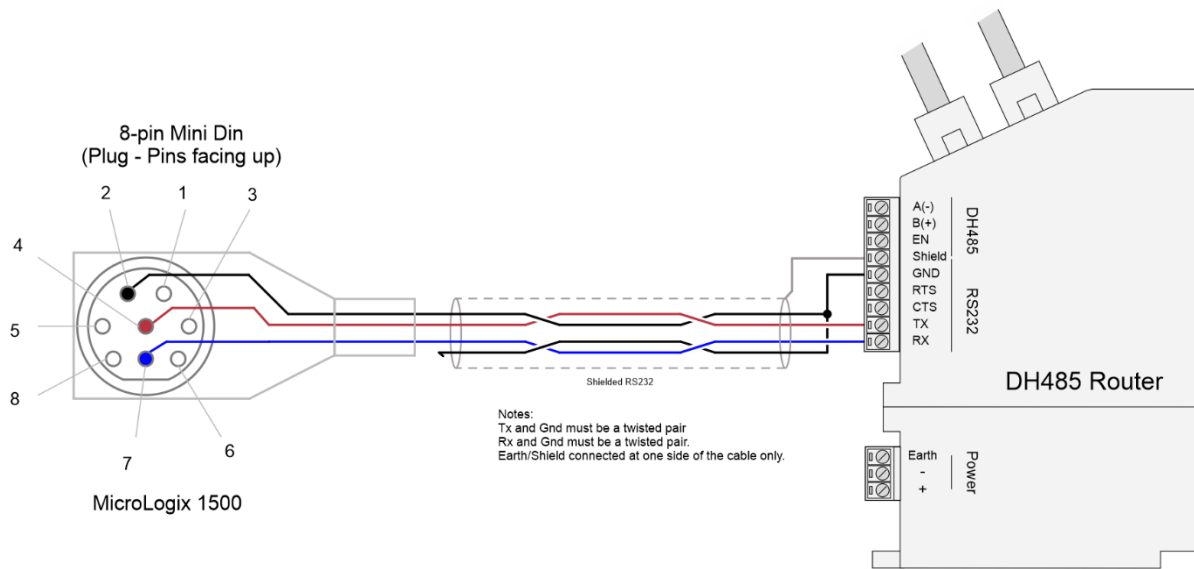

Figure 7.4 – DH485R/B – MicroLogix 1500 (RS232)

## 7.5. DH485R/B – SLC5/04 (RS232)

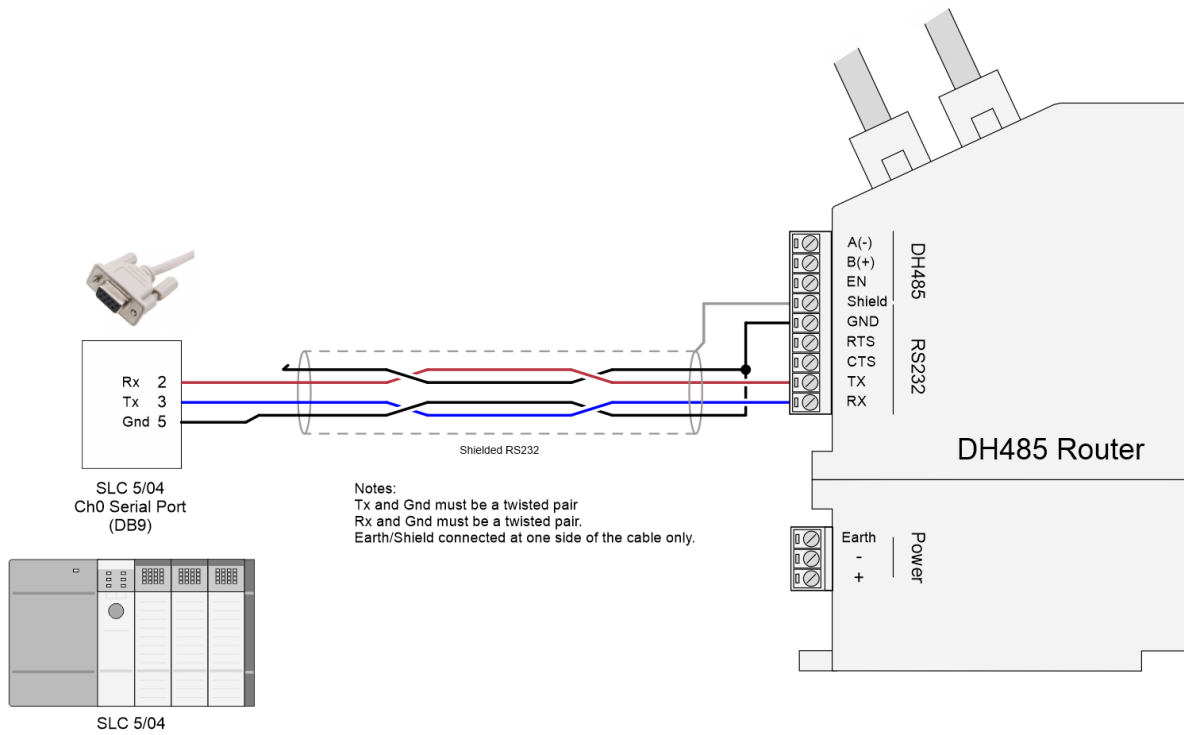

Figure 7.5 – DH485R/B – SLC5/04 (RS232)

## 8. INDEX

### A

Advanced configuration, 29  
assembly instance, 51

### C

CompactLogix, 11  
Contact Us, 12  
ControlLogix, 9

### D

DC power, 13  
DH485 general configuration, 26  
DH485 parameters, 26  
DH485 Router, 1, 5, 8, 24, 27, 33, 37, 38, 40, 50, 51, 55,  
65, 70, 71, 78, 79  
DHCP, 14, 18  
dimensions, 79, 83, 85  
DIN rail, 15, 79  
DIP, 14

### E

Ethernet Bridge, 50  
Ethernet connector, 17  
EtherNet/IP, 5, 11

### F

File Number, 40, 41, 43, 44, 45, 47  
firmware upgrade, 26

### I

input assembly, 56, 68  
input voltage, 16

### L

LED, 64, 65

Logix tag, 27, 37, 39, 40, 41, 43, 44, 45, 47, 55, 57, 59  
Logix Tag Map, 40, 43

### M

Modbus Router, 17, 64

### O

output assembly, 55, 57, 58, 67

### R

requested packet interval (RPI), 52  
Rockwell Automation, 22, 39  
RS232, 13, 16, 17, 29, 38  
RS232/RS485, 16  
RSLinx, 22  
RSLogix 5000, 37, 39, 50, 52, 54, 55, 57, 58, 78

### S

Safe Mode, 14  
Serial, 81  
Slate, 25, 26, 42, 43, 47, 56, 65, 78  
SLC, 5, 11, 38, 39  
statistics, 65, 70, 71  
Support email, 12

### T

**Transparent mode**, 27, 82

### U

User Defined Types (UDTs), 52

### W

web server, 65, 78