

DATASHEET

EtherNet/IP™ to DH+ Gateway AN-X4-AB-DHRIO

The AN-X4-AB-DHRIO Gateway is designed to help customers initiate a phased migration approach to replacing or upgrading legacy PLC's, HMI's, Drives, or Flex I/O adapters.

These solutions can be achieved by selecting the corresponding operating mode during initial configuration. The AN-X4-AB-DHRIO has a built-in webserver to view diagnostics, current configuration, upload configuration files, and set the operating mode. It is also DIN Rail Mountable.



DH+ to EtherNet/IP™

Engineering Terminal



This operating mode acts as a bridge between an EtherNet/IP and a DH+ network.

- Programming terminals, and/or processors on an EtherNet/IP network can access legacy processors on a DH+ network
- Download to a PLC5 or SLC through RSLinx
- Configured through web browser
- Supports all DH+ baud rates (57.6, 115.2, and 230.4 K baud)



This operating mode helps the communication between an Ethernet-based processor with legacy processors on a DH+ network.

- Supports gathering data without changing existing PLC or SLC hardware

DH+ to Modbus TCP

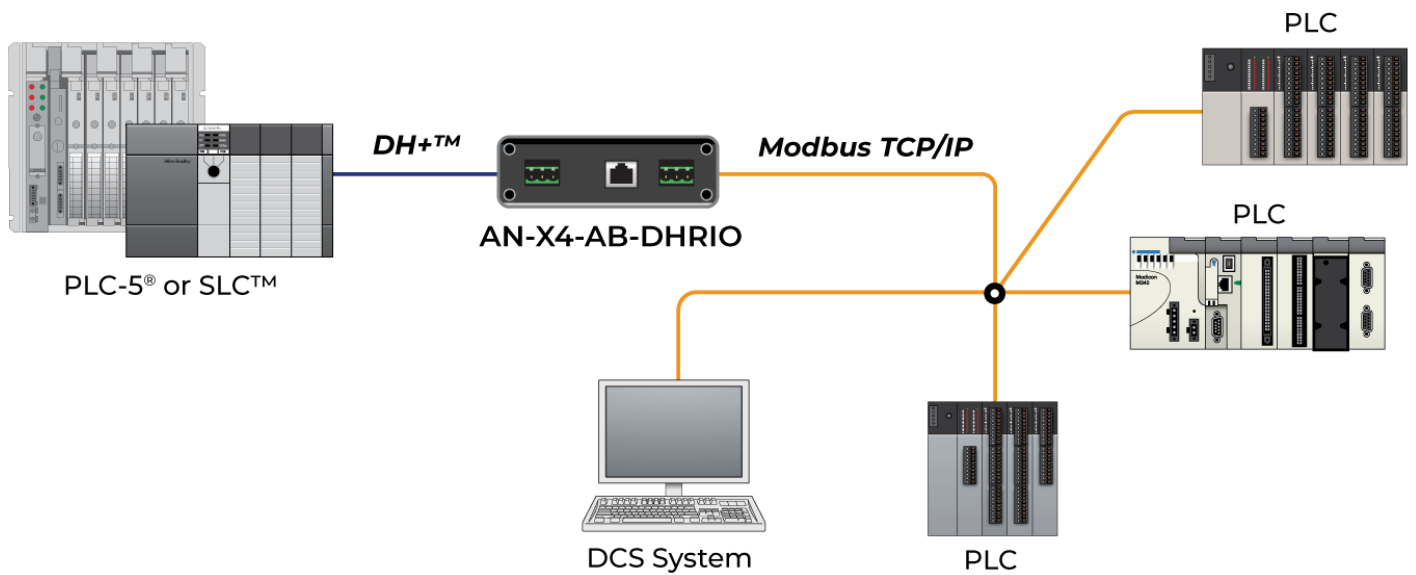

This operating mode allows Modbus TCP Clients to access the PLC data from stations on a Data Highway Plus Network.

- The Modbus TCP server supports up to 128 connections
- Modbus Input and Output Registers are mapped to the PLC/SLC files for each station
- Modbus TCP Unit/Slave ID data is mapped to the Data Highway Plus Station

HMI



This operating mode allows legacy PanelViews to be upgraded to a PanelView Plus 6 or PanelView Plus 7 via EtherNet/IP.

- No changes to PLC code required
- Supports up to 8 PanelViews on the same network

Drive

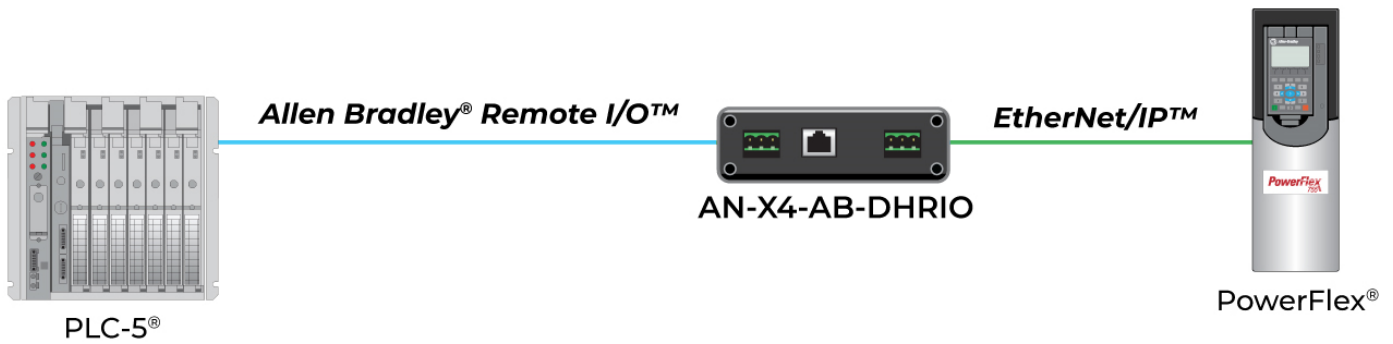

This operating mode supports upgrading legacy Allen Bradley drives on Remote I/O to new EtherNet/IP-enabled drives.

- No changes to PLC code required
- Supports up to 4 EtherNet/IP drives
- Configurable with ¼, ½, and full rack addressing
- Supports all PowerFlex drives on EtherNet/IP

Flex I/O Scanner

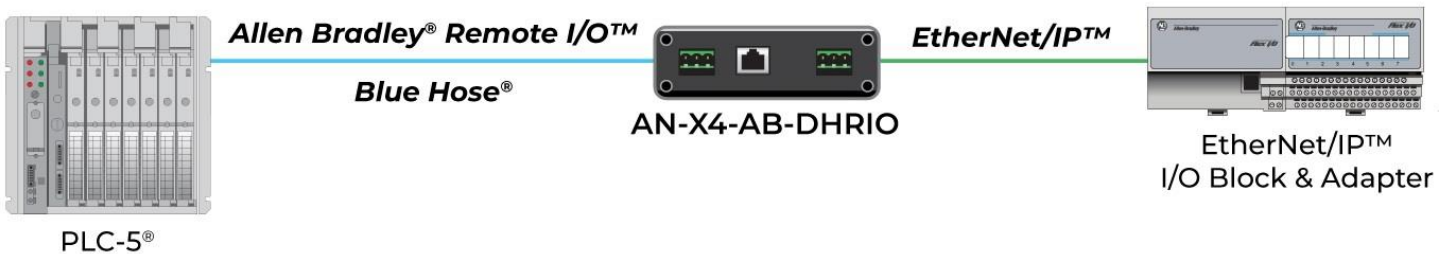

This operating mode allows PLC's on Remote I/O to connect to and control 1794-AENT EtherNet/IP Flex adapters.

- Designed to replace obsolete 1794-ASB adapters
- Supports up to 16 EtherNet/IP connections
- Each adapter and rack of discrete counts as a single connection. Each analog module counts as a single connection.

Remote I/O Scanner

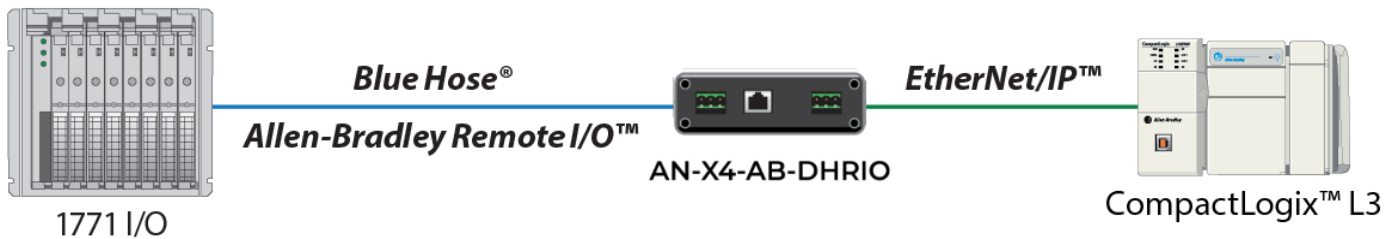

This operating mode allows users to replace their existing Remote I/O PLC with a ControlLogix or CompactLogix PAC without having to replace existing racks of I/O.

- Build new controller programs without interrupting existing controls, minimizing downtime
- Supports up to 32 racks of Remote I/O
- Supports all Remote I/O baud rates (57.6, 115.2, and 230.4 K baud), and Remote I/O addressing 0 to 76 octal
- Auto-Configuration utility discovers baud rate and maps discrete I/O, reducing configuration errors

Bridge Mode

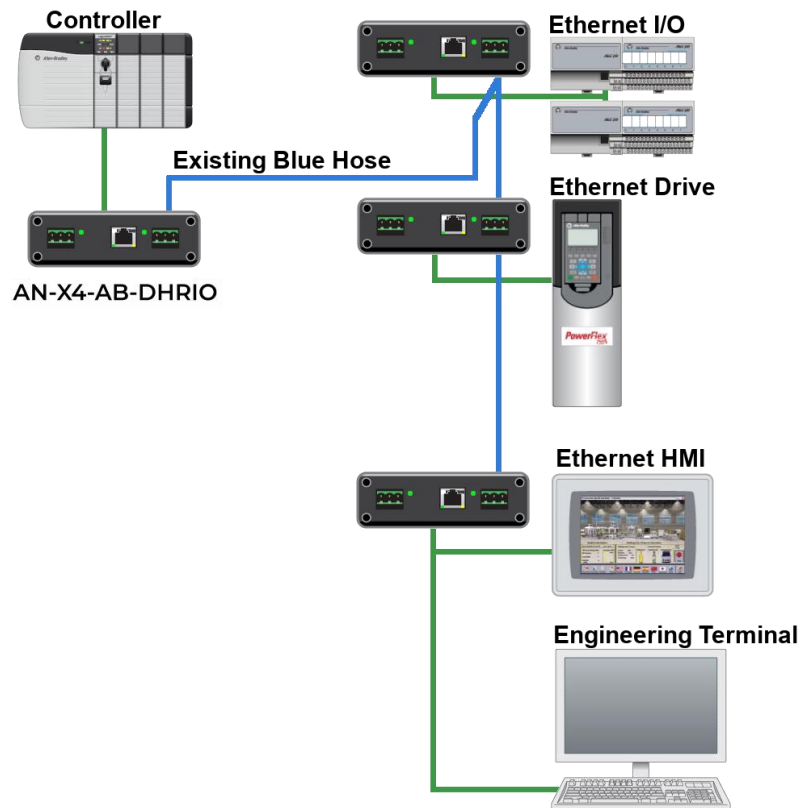

This operating mode allows the module to listen to all messages on an Ethernet network and use its "BridgeIP" mapping to forward the messages out of the DH+/BH port. The messages received on the DH+/BH port can be forwarded to the devices connected to its Ethernet port.

- Allows the use of existing Blue Hose cabling for EtherNet/IP communication:
 - I/O to Controllers
 - HMI to SCADA
 - Programming Controllers via PC
- Support for up to 64 AN-X4-BRG, each on different Ethernet network
- DH+ mode supports up to 230k Baud Rate
- Blue Hose mode supports up to 460K Baud Rate

Hardware Specifications

| Specification | Description |
|---------------------------|--|
| Ports | 1 RJ45 10/100 Mbps Ethernet port 1 Phoenix 3-pin power connector 1 Phoenix 3-pin connector network connector |
| Typical Power Consumption | 240 mA @ 12 Vdc or 120 mA @ 24 Vdc |
| Maximum Power Dissipation | 2.9 W |
| Operating Temp | 32°F to 122°F (0 °C to 50 °C) |
| Storage Temperature | -40°F to 185°F (-40 °C to 85 °C) |
| Dimensions | 107 x 98 x 34 mm (4.18 x 3.86 x 1.33 in) Not including connectors |
| Humidity | 5% to 95% RH, with no condensation |

Agency Approvals and Certifications

Please visit our website: www.prosoft-technology.com



Where Automation
Connects™

Ordering Information

To order this product, please use the following:

EtherNet/IP™ to DH+
Gateway

AN-X4-AB-DHRIO

To place an order, please contact your local ProSoft Technology distributor. For a list of ProSoft Technology distributors near you, go to:

www.prosoft-technology.com
and select *Where to Buy* from the menu.

Copyright © 2024 ProSoft Technology, Inc.
All Rights Reserved. May 3, 2024
For Public Use.

Specifications subject to change without notice.