

## DeviceNet Router Series B A-DNTR/B

The DeviceNet Router/B provides a powerful and easy to configure solution to exchange data between DeviceNet™ and EtherNet/IP™, Modbus TCP/IP or Modbus RTU networks. The module can be configured as a DeviceNet Scanner or a DeviceNet Device - allowing the user to not only integrate DeviceNet devices into a Logix or Modbus system, it also allows EtherNet/IP or Modbus devices in an existing DeviceNet network.

As a **DeviceNet Scanner**, the module can connect to over 63 DeviceNet devices where the cyclic input/output data from each device can be mapped to an EtherNet/IP Target/Originator or a Modbus Server/Client. The module can be configured to exchange explicit messages with DeviceNet nodes.

As a **DeviceNet Device**, the module supports input/output data sizes of up to 256 bytes using polled or change-of-state connections.

In **PCCC Client mode**, the module can asynchronously exchange data between a DeviceNet Scanner and an Ethernet PCCC device.

As an **EtherNet/IP Target**, the module supports the following method to read/write data from an EtherNet/IP network.

- With support for **EtherNet/IP Class 1** connection, DeviceNet data can be mapped to an input and output Class 1 cyclic connection to the Logix controller.

As a **EtherNet/IP Originator**, the module supports three methods to read/write data from an EtherNet/IP network:

- With support for **EtherNet/IP Explicit** messaging, the router can use Class 3 or unconnected messages (UCMM) to send/receive data from remote EtherNet/IP devices.
- With support for **Direct-To-Tag technology**, DeviceNet data can be read from or written to Logix tags without the need for code in the Logix controllers.
- With support for **EtherNet/IP Class 1** connection, the router can own up to a maximum of 10 EtherNet/IP devices and exchange DeviceNet data using the device's input/output assemblies.

As a **Modbus Server**, DeviceNet data can be written to the module's internal Modbus registers. These registers can be accessed by a remote Modbus client using the Modbus TCP/IP or RTU protocol.

As a **Modbus Client**, DeviceNet data can be written to the module's internal Modbus registers. The integrated Modbus auxiliary mapping feature can be used to configure Modbus data exchange between multiple Modbus server devices and the module's internal Modbus registers using the Modbus TCP/IP or RTU protocol.

The DeviceNet Router B is configured using the Slate Configuration Utility software tool.

The DeviceNet Router B includes a webserver to display DeviceNet operation and communication statistics and advanced diagnostics functions like built-in packet capture for the various protocols. The router has two Ethernet ports to support Device-Level-Ring (DLR) architectures.



## Features

- ❖ DeviceNet Scanner or DeviceNet Device
- ❖ Support for multiple DeviceNet network baud rates (125K, 250K, 500K)
- ❖ Support for DeviceNet pass-through or explicit messaging
- ❖ PCCC client mode to connect to Ethernet-only PanelViews to an existing DeviceNet network
- ❖ EtherNet/IP Target or Originator with support for Class 1 connections
- ❖ Supports Modbus TCP/IP (Ethernet) and Modbus RTU (Serial) Client/Server
- ❖ Direct-to-Tag Technology
- ❖ Dual Ethernet ports with support for DLR (Device Level Ring)
- ❖ Support for NTP (Network Time Protocol) for external clock synchronization
- ❖ Advanced Diagnostics, including packet capture

## Configuration

- ❖ The Slate Configuration Utility software is used for configuration and troubleshooting of the module. The stand-alone configuration utility allows users to define the setup and configuration of the DeviceNet Router module, connections with controllers and devices.
- ❖ The Slate Configuration Utility software can be downloaded from [www.prosoft-technology.com](http://www.prosoft-technology.com)

The following example shows the DeviceNet Router B, configured to connect DeviceNet Devices to an EtherNet/IP-enabled device (e.g. Logix controller).

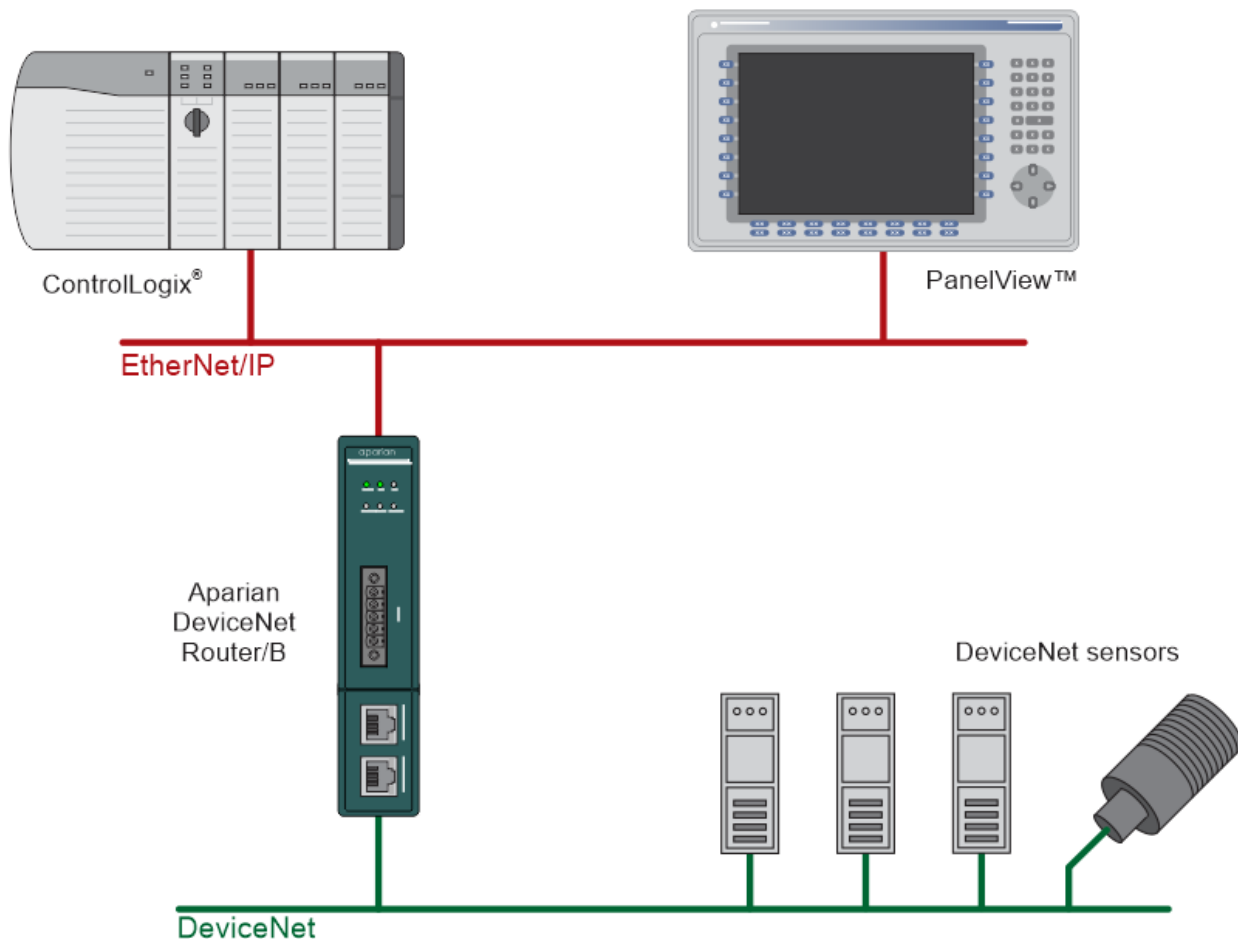

The following example includes a Modbus RTU device using the module to emulate a DeviceNet device to communicate with the DeviceNet Controller.

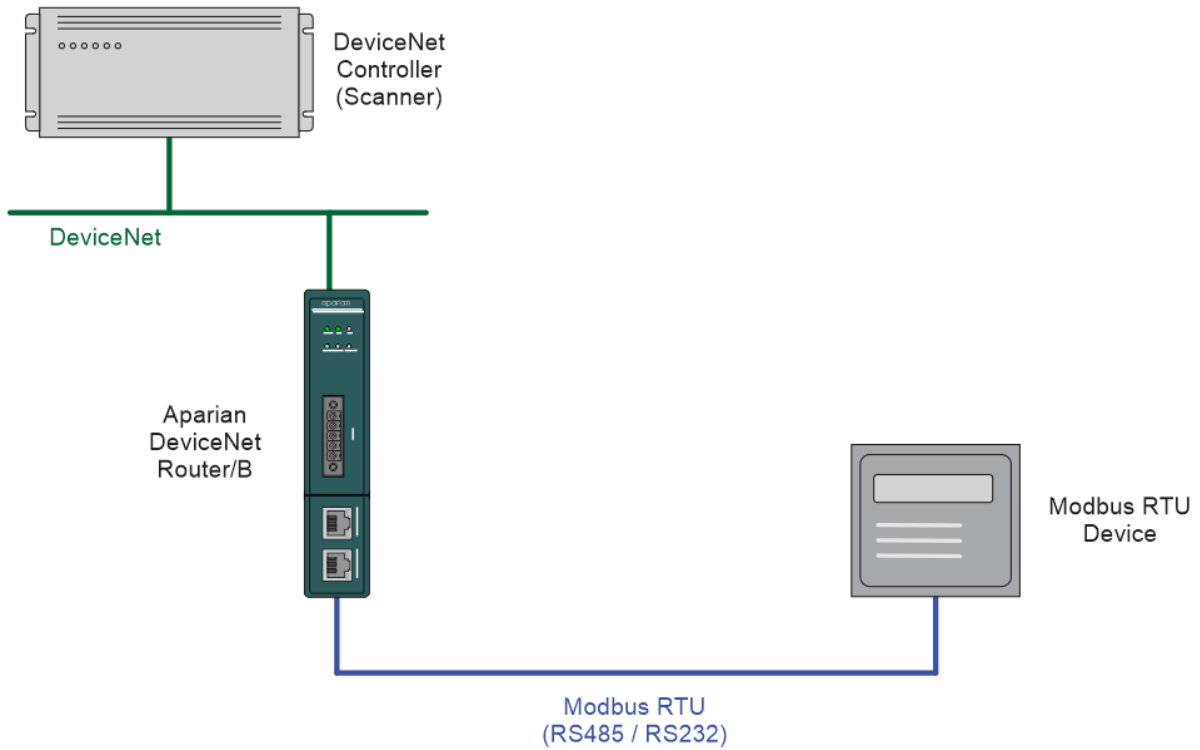

The following example includes EtherNet/IP devices (Drive and Overload relay) using the module to emulate a DeviceNet device to communicate with the DeviceNet controller (scanner).

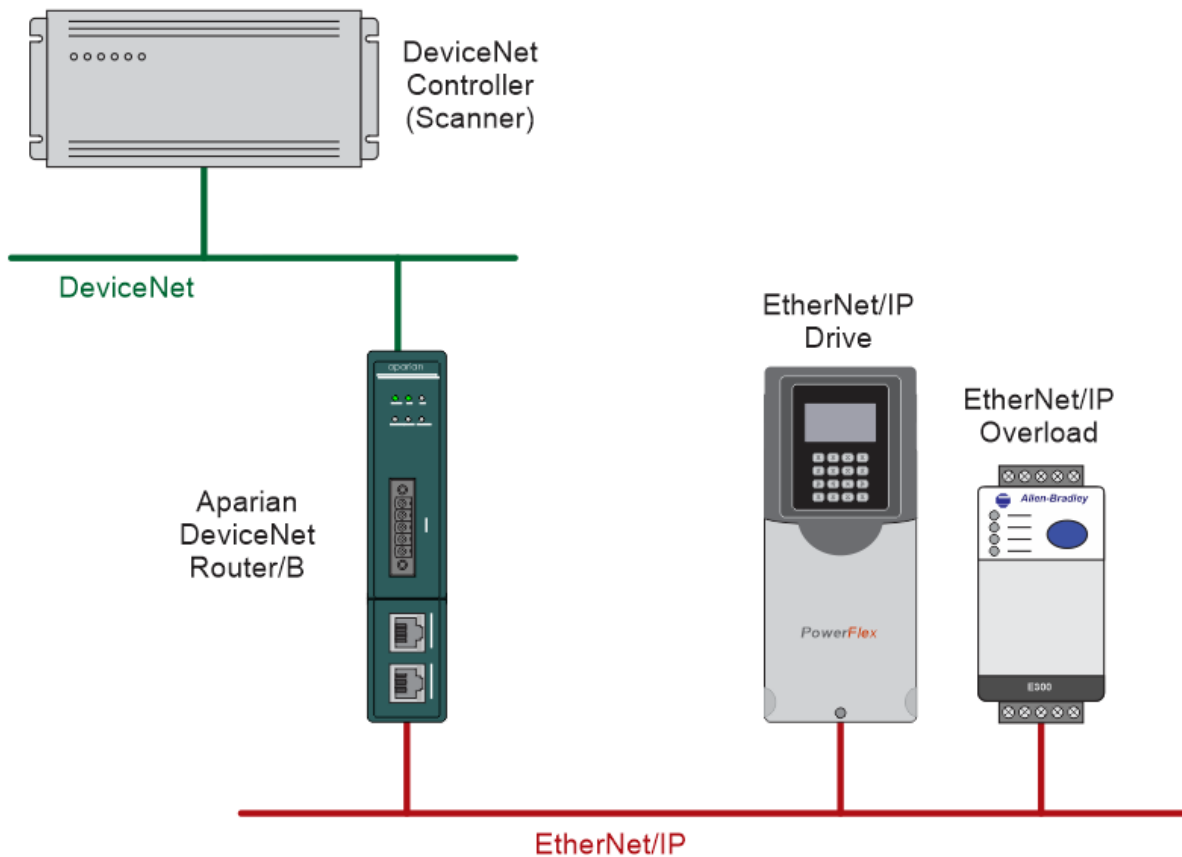

## Specifications

### DeviceNet Network

Specification	Description
Connector	5-way terminal, 5.08 mm pitch.
Modes	Scanner, Target (or Device)
Baud Rate	125k, 250k, 500k
DeviceNet Terminator	120 $\Omega$ (Software enabled)

### DeviceNet Scanner

Specification	Description
Device Count	63
Set Target Device Node	Supported
Set Target Device Baud Rate	Supported
Device Discovery	Supported
Explicit Messaging	Supported
Supported Connections	Poll, Change of State (COS)

### DeviceNet Target

Specification	Description
Supported Connections	Poll, Change of State (COS)
Input / Output Data Max	256 bytes input or output, per message

### PCCC Network

Specification	Description
Max PCCC Connections	10
Max PCCC Payload	1000 bytes

### EtherNet/IP Network

Specification	Description
Connector	RJ45
Conductors	CAT5 STP/UTP
ARP Connections	Max 100
TCP Connections	Max 100
CIP Connections	Max 15
Communication Rate	10/100 Mbps
Duplex Mode	Full / Half
Auto-MDIX Support	Yes
Embedded switch	Yes, 2 x Ethernet ports
Device Level Ring (DLR)	Yes
Network Time Protocol (NTP)	Yes



Where Automation  
Connects™

## Global Distribution

ProSoft Technology® products are distributed and supported worldwide through a network of over 500 distributors in over 50 countries. Our knowledgeable distributors are familiar with your application needs. For a complete list of distributors, go to our website at: [www.prosoft-technology.com](http://www.prosoft-technology.com)

## Global Support

We are there for you

All ProSoft Technology products are backed with free technical support. Contact our worldwide Technical Support team directly by phone or email.

## Global Offices

We are where you are

ProSoft Technology has regional offices worldwide available to help you with all your industrial application needs. If you need help choosing a ProSoft Technology solution for your particular application check out our contact information under distributor sales on the website at: [www.prosoft-technology.com](http://www.prosoft-technology.com)

Whether your application is large or small, our technical professionals are there to help you choose the right communication solution.

## EtherNet/IP Originator

Specification	Description
Class 1 Cyclic Connections Supported	Yes
Class 3 / UCMM Connections Supported	Yes
Class 1 connection count	10
Class 3 / UCMM Target Device Count	10
Class 3 / UCMM Mapping Count	50

## EtherNet/IP Target

Specification	Description
Class 1 Cyclic connection count	4
Logix Direct-To-Tag supported	Yes

## Modbus Client

Specification	Description
Modes	Modbus TCP/IP, Modbus RTU (RS232 and 485)
Modbus RS485 Termination	125 $\Omega$ (Software enabled)
Maximum Modbus Server Devices	20
Maximum Modbus Registers mapped	100
Modbus address Range supported	0 to 65535 of each type (Holding/Input Register, Input/Coil Status)
Base Offset	Modbus (Base 0) ; PLC (Base 1)
Configurable Modbus TCP port	Yes
Data Reformatting Supported	BB AA BB AA DD CC CC DD AA BB DD CC BB AA

## Modbus Server

Specification	Description
Modes	Modbus TCP/IP, Modbus RTU (232 and 485)
Modbus RS485 Termination	Software set
Modbus address Range supported	0 to 65535 of each type (Holding/Input Register, Input/Coil Status)
Base Offset	Modbus (Base 0) ; PLC (Base 1)
Configurable Modbus TCP/IP port	Yes



Where Automation Connects™

## Global Distribution

ProSoft Technology® products are distributed and supported worldwide through a network of over 500 distributors in over 50 countries. Our knowledgeable distributors are familiar with your application needs. For a complete list of distributors, go to our website at: [www.prosoft-technology.com](http://www.prosoft-technology.com)

## Global Support

We are there for you

All ProSoft Technology products are backed with free technical support. Contact our worldwide Technical Support team directly by phone or email.

## Global Offices

We are where you are

ProSoft Technology has regional offices worldwide available to help you with all your industrial application needs. If you need help choosing a ProSoft Technology solution for your particular application check out our contact information under distributor sales on the website at: [www.prosoft-technology.com](http://www.prosoft-technology.com)

Whether your application is large or small, our technical professionals are there to help you choose the right communication solution.

## Serial Port (RS232)

Specification	Description
RS232 Connector	9-way terminal (shared with RS485)
RS232 Conductor	24 – 18 AWG
Electrical Isolation	1000 VDC
Baud Rates	1200, 2400, 4800, 9600, 19200, 38400, 57600, 115200
Parity/Data Bits/Stop Bits	None, Even, Odd / 8 / 1

## Serial Port (RS485)

Specification	Description
RS232 Connector	9-way terminal (shared with RS485)
RS232 Conductor	24 – 18 AWG
Electrical Isolation	1500 Vrms (1 minute, maximum)
Baud Rates	1200, 2400, 4800, 9600, 19200, 38400, 57600, 115200
Parity/Data Bits/Stop Bits	None, Even, Odd / 8 / 1

## Hardware

Specification	Description
Power Supply	Input: 10 to 32 VDC, (85 mA @ 24 VDC and 180mA @ 10 VDC)
Power Consumption	2.2 W
Dimensions	149.0 x 34.0 x 116.0 mm (H x W x D)
Connector	3-way terminal
Conductors	24 to 18 AWG
Enclosure Rating	IP20, NEMA/UL Open Type
Temperature	-20 to 70 °C
Humidity	0 to 95% RH, non-condensing
Earth Connection	Yes, terminal based
Emissions	IEC61000-6-4
ESD Immunity	EN 61000-4-2
Radiated RF Immunity	IEC 61000-4-3
EFT/B Immunity	IEC 61000-4-4
Surge Immunity	IEC 61000-4-5
Conducted RF Immunity	IEC 61000-4-6

## Agency Approvals & Certifications

Please visit our website: [www.prosoft-technology.com](http://www.prosoft-technology.com)



Where Automation  
Connects™

## Ordering Information

To order this product, please use the following:

## DeviceNet Router/B

A-DNTR/B

To place an order, please contact your local ProSoft Technology distributor. For a list of ProSoft Technology distributors near you, go to:

[www.prosoft-technology.com](http://www.prosoft-technology.com)

and select *Where to Buy* from the menu.

Copyright © 2023 ProSoft Technology, Inc.

All Rights Reserved. February 1, 2023

Specifications subject to change without notice.